



Product Features

- for hydraulic balancing of hot water return systems (PWH-C)
- wetted metal parts made from dezincification-free and corrosion-resistant gunmetal, resistant against aggressive water
- PTFE seat gasket
- maintenance-free spindle gasket with self-lubricating EPDM lip gasket
- male union thread
- with plugged Drain Port
- incl. thermometer
- with pocket for temperature sensor Pt1000
- free from dead spots
- keeps throttle pre-setting when valve is closed and opened
- with indicator for pre-setting

Standards and Approvals

- DVGW approval
- ÖVGW approval
- SVGW approval
- WRAS approval
- KIWA approval
- plastic parts with KTW and W 270 approval
- for systems according to DVGW worksheet W 551 / W 553 / DIN 1988-300
- according to accepted materials list from German environmental agency
- DIN EN 1213
- ÜA-Reg.-Nr. R-15.2.3-21-17048, WIEN-ZERT

Technical Data

- pressure rating PN 16
- max. operating temperature 100 °C

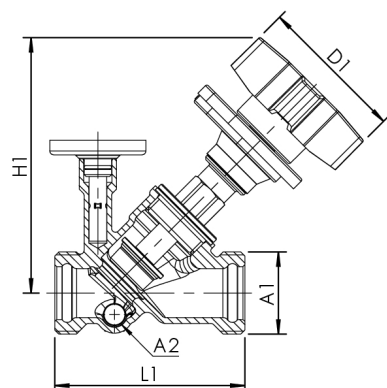

part no.	DN	A1	A2	D1 (mm)	H1 (mm)	L1 (mm)	cv (m³/h)	kg
1506G01500	15	G 3/4	G 1/4	75,5	116	70	4,48	0,569
1506G02000	20	G 1	G 1/4	75,5	123	78,5	6,28	0,759
1506G02500	25	G 1 1/4	G 1/4	75,5	130	97	10,81	1,022
1506G03200	32	G 1 1/2	G 1/4	75,5	131	110	15,56	1,393
1506G04000	40	G 1 3/4	G 1/4	75,5	138	130	19,19	1,8
1506G05000	50	G 2 3/8	G 1/4	75,5	150	145	20,72	2,637

accessory

gunmetal sampling valve, figure 187 00
 insulation shell for MULTI-FIX-PLUS double-regulating valve, as of 01/2017, figure 471 26
 drain valve made of gunmetal/plastic, figure J7109 173 00
 Pt 1000 temperature sensor, figure T5100 140 00
 gunmetal solder union connector, figure 476 04
 gunmetal union connector, union nut, FPT, figure 476 06
 gunmetal union connector, union nut, FPT, with drain valve, figure 476 07
 gunmetal union connector, union nut, MPT, figure 476 08
 solder / pressfit union connector, figure 476 14
 pressfit union connector, MAPRESS stainless steel and copper, figure 476 22
 pressfit union connector, SANPRESS and PROFIPRESS, figure 476 30
 pressfit union connector, SANHA and NiroSan, figure 476 35
 pressfit union connector, MEPLA, figure 476 40
 pressfit union connector, MAPRESS stainless steel, figure 476 20
 pressfit union connector, SANPRESS INOX, figure 476 70
 pressfit union connector for Viega RAXOFIX, figure 476 32