

Electronic mixing valve with programmable thermal disinfection

6000 series



01086/20 EN

replaces dp 01086/12 EN



LEGIOMI



Function

The electronic mixing valve is used in centralised systems that produce and distribute domestic hot water.

Its function is to guarantee and maintain the temperature of the domestic hot water delivered to the user when there are variations in the temperature and pressure of the hot and cold water at the inlet or in the draw-off flow rate.

This particular series of electronic mixing valves is equipped with a **specific regulator that controls a set of programs for circuit thermal disinfection against Legionella.**

It also allows **checking that the thermal disinfection temperature and time are actually reached and means the appropriate corrective action can be taken.** All the parameters are updated every day and logged, with temperatures recorded every hour.

Depending on the type of system and habits of the user, it is possible to program temperature levels and operation times in the most appropriate manner.

In addition, it is fitted for a monitoring and remote control connection.

PATENT PENDING

Product range

6000 series Electronic mixing valve with programmable thermal disinfection. Threaded version. _____ sizes 3/4"; 1"; 1 1/4"; 1 1/2"; 2"
 6000 series Electronic mixing valve with programmable thermal disinfection. Flanged version. _____ sizes DN 65 and DN 80

Technical specifications

Valve body

Materials:
 Body: brass UNI EN 12165 CW617N
 Ball: - 3/4"-1 1/4" versions: brass EN 12164 CW614N, chrome plated
 - 1 1/2" and 2" versions: brass EN 12164 CW614N, chrome plated,
 POM
 - flanged versions: stainless steel AISI 316
 Hydraulic seals: threaded versions: EPDM - flanged versions: NBR

Maximum working pressure (static): 10 bar
 Maximum inlet temperature: 100 °C
 Temperature gauge scale: 0-80 °C

Hot and cold water connections: 3/4"-2" M with union
 Mixed water connection: 3/4"-2" F
 Flanged connections: DN 65 and DN 80, PN 16 can be coupled with counterflange EN 10921

Actuator for threaded version

Electric supply: 230 V (ac) - 50/60 Hz directly from the regulator
 Power consumption: 6 VA
 Protection cover: self-extinguishing V0
 Protection class: IP 65
 Ambient temperature range: -10-55 °C
 Supply cable length: 0,8 m

Actuator for flanged version

Electric supply: 230 V (ac) - 50/60 Hz directly from the regulator
 Power consumption: 10,5 VA
 Protection cover: self-extinguishing V0
 Protection class: IP 65
 Ambient temperature range: -10-55 °C
 Supply cable length: 2 m

Digital regulator

Material: self-extinguishing ABS, white RAL 1467
 Housing: self-extinguishing SAN, smoked transparent
 Cover: 230 V (ac) 50/60 Hz
 Electric supply: 6,5 VA
 Power consumption: 20-85 °C
 Adjustment temperature range: 40-85 °C
 Disinfection temperature range: 0-50 °C
 Ambient temperature range: IP 54 (wall mounting) (Class II appliance)
 Protection class:
 Contact rating: 5(2) A / 250 V
 Mixing valve control: 5(2) A / 250 V
 Alarm relay (R2): 10(2) A / 250 V
 Relay 1, 3, 4:

Fuses: 1 (main): 80 mA
 Fuses: 2 (mixing valve): 1 A
 Charge reserve: 15 days in the event of electric supply failure, with a 3-cell rechargeable 150 mAh buffer battery

Enabled by microswitch.
 Battery recharging time: 72 h
 Conforms to Directives: CE

Temperature probes

Material: stainless steel
 Body: NTC
 Type of sensitive element: -10-125 °C
 Working temperature range: 10000 Ohm at 25 °C
 Resistance: 2.5
 Time constant: 150 m with 2x1 mm² cable
 Max. distance for flow or recirculation probe: 250 m with 2x1,5 mm² cable

Dimensions

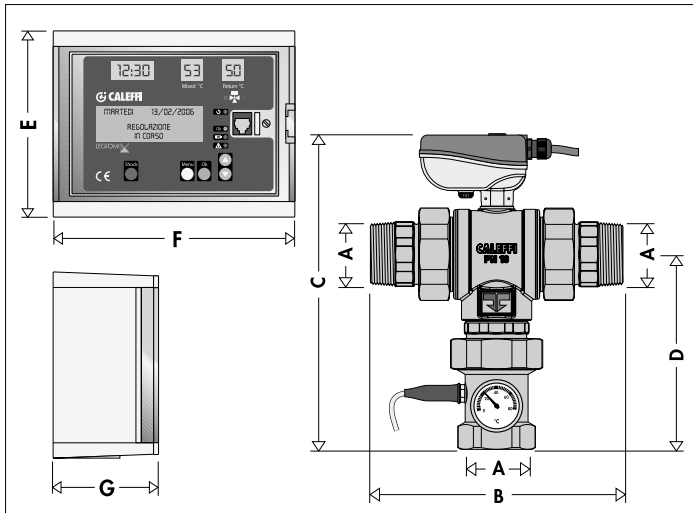

Code	A	B	C	D	E	F	G	Mass (kg)
600051	3/4"	135	216	102.5	145	180	105	2.4
600061	1"	159	237	106.5	145	180	105	3.3
600071	1 1/4"	184	257	113.5	145	180	105	3.7
600081	1 1/2"	232	306	181	145	180	105	9.5
600091	2"	240	311	186	145	180	105	9.7

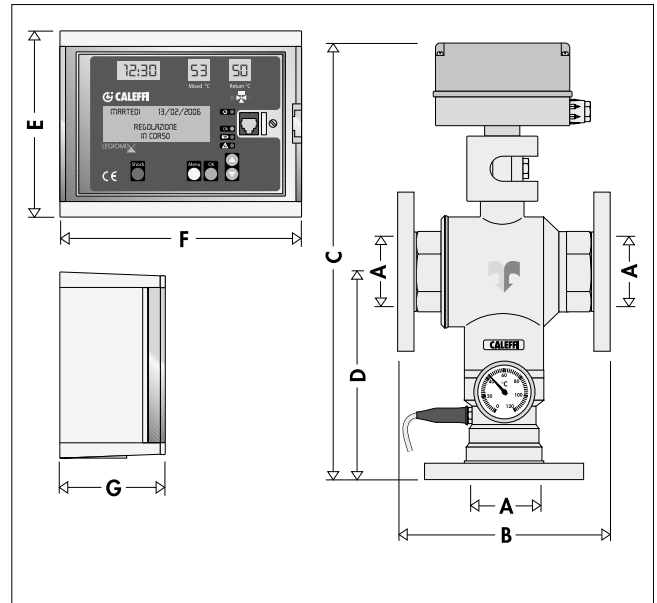

Code	A	B	C	D	E	F	G	Mass (kg)
600006	DN 65	235	600	275	145	180	105	28
600008	DN 80	235	600	275	145	180	105	30.4

Legionella-distribution temperature

In central systems that produce hot water with storage for domestic purposes, in order to prevent the proliferation of dangerous Legionella bacteria, the hot water must be stored at a temperature of at least 60 °C. At this temperature it is certain that the proliferation of the bacteria that cause Legionnaire's disease will be totally inhibited.

These temperatures, however, are too high for direct use by the user; water at these levels can cause severe burns. It is therefore necessary to reduce the temperature of the hot water distributed to the user to a lower value suitable for use.

Moreover, not only the storage but also the entire distribution network requires thermal disinfection at regular intervals. Otherwise the bacteria would develop quickly in there too.

In view of the above, it is therefore necessary to use an electronic mixing valve able to:

- reduce the temperature of the distributed water to an adjustable value which is lower than the storage temperature
- keep the mixed water temperature constant despite any variation in inlet temperature and pressure, or in the drawn-off flow rate.
- program thermal disinfection with a higher temperature than the regulation value, within the necessary time and during periods with less frequent consumption (night-time).

Thermal disinfection

The adjacent diagram shows the behaviour of *Legionella Pneumophila* bacteria as the temperature conditions of the water containing the bacteria vary, in laboratory cultures.

To ensure correct thermal disinfection, it is necessary to go up to values of at least 60 °C.

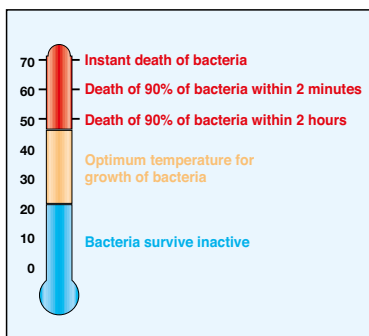

Energy saving

Energy savings are governed in Italy by Presidential Decree no. 412/93 making it compulsory to use mixing valves on domestic water systems with storage, which are not otherwise regulated, in order to limit the temperature of the water at the inlet of the distribution network to 48 °C with a tolerance of +5 °C. The purpose of limiting the temperature is to reduce passive thermal losses through the distribution network as much as possible and to prevent the delivery of water at a higher temperature than necessary.

Reference documents

With regard to the prevention and control of Legionella, see the National Regulations and applicable Code of Practice.

- 1) "Guidelines for the prevention and control of Legionnaire's disease set out by the Ministry of Health and adopted by the Conference of State and Regional Authorities on 4/4/2000". Published in the Gazzetta Ufficiale (Official Gazette) No. 103 dated 5th May 2000.
- 2) "Guidelines giving information on Legionnaire's disease for managers of tourist, hospitality and spa facilities", Provisions dated 13 January 2005. Published in the Gazzetta Ufficiale (Official Gazette) No. 51 dated 3 March 2005.
- 3) "Guidelines giving instructions for laboratories providing microbiological diagnosis and environmental monitoring for Legionella". Provision dated 13 January 2005. Published in the Gazzetta Ufficiale (Official Gazette) No. 51 dated 3 March 2005.

Applications

The electronic mixing valve is typically used in central systems serving hospitals, nursing homes, sports centres, shopping centres, hotels, campsites and boarding schools. In these structures with their collective use, it is more than ever necessary to control and prevent legionnaire's disease in a programmed manner, managing the disinfection times in the best possible way.

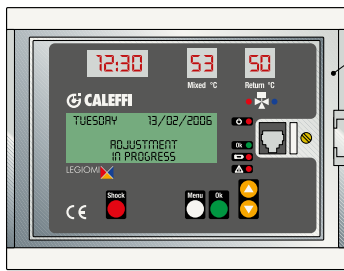

Characteristic components

- 1 LEGIOMIX® digital regulator
- 2 Mixing valve
- 3 Mixing valve actuator
- 4 Mixed water flow probe
- 5 Recirculation probe
- 6 Mixed water flow temperature gauge

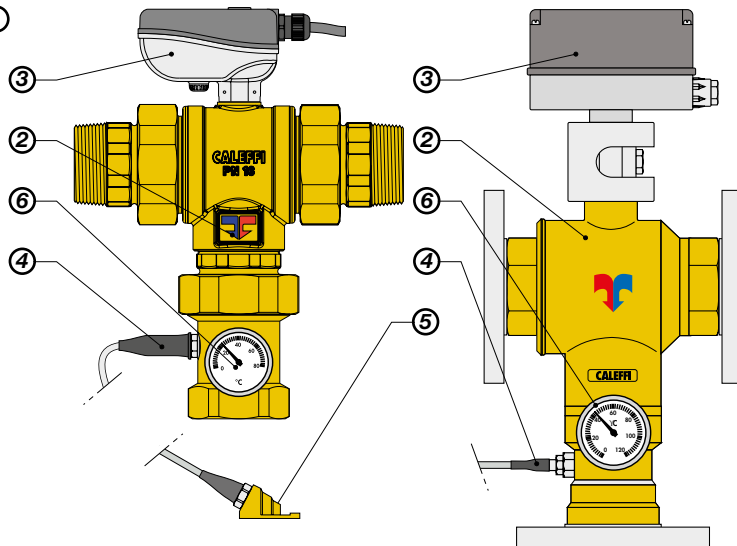

Operating principle

At the inlets the mixing valve has the hot water from the storage and the cold water from the water mains. At the outlet there is the flow mixed water. By means of a specific probe, the regulator measures the temperature of the mixed water at the valve outlet and actuates the mixing valve in order to maintain the set temperature.

It modifies the flows of hot and cold water at the inlet to bring the temperature of the outlet water to the adjusted value.

Even if there are drops in pressure due to hot or cold water usage or temperature variations at the inlet, the mixing valve automatically adjusts the water flow rates until the set temperature is reached.

The regulator incorporates a digital clock and allows programming anti-legionella disinfection treatment for the hydraulic system.

The system is disinfected by raising the water temperature to a specific value for a specific time duration.

For **the best thermal disinfection control**, in this type of system it may also be necessary to measure the temperature of the water returning from the distribution network, **using the recirculation probe**. When this measurement is available, it is used to **check and control the temperature reached over all or part** of the network, since the probe may be located at a significant remote point of the system.

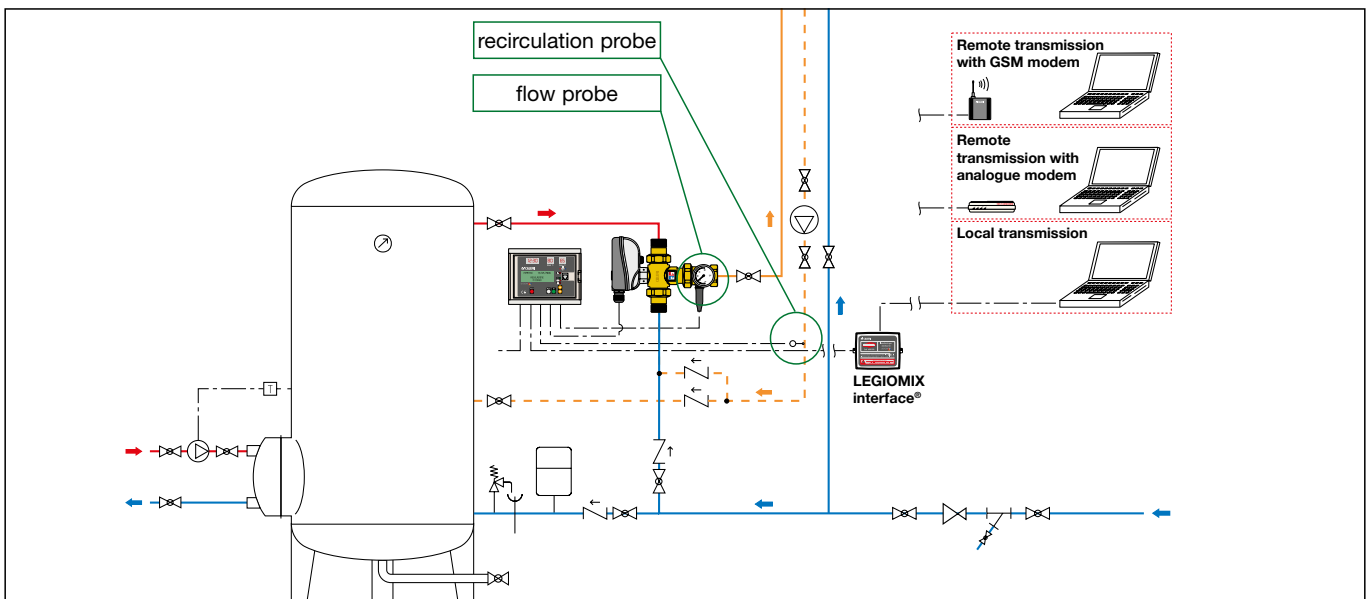
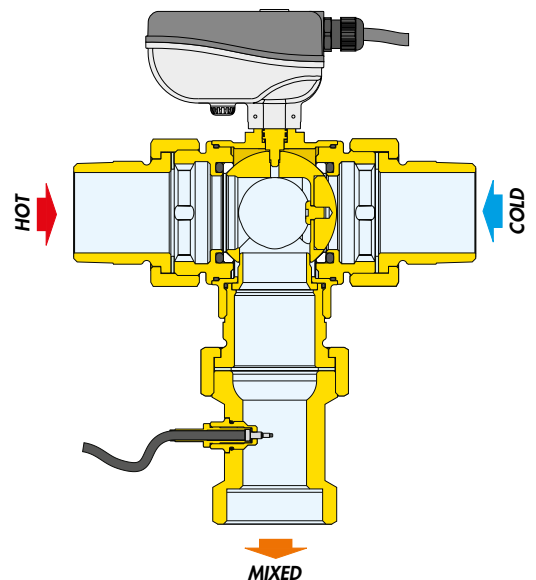

Interface for remote control

The LEGIOMIX® interface (code DA CONTROLLARE 600100) allows the transfer of data to personal computers, both with local connection and with remote transmission via analogue modem or GSM, used for remote querying and setting.

Hydraulic characteristics

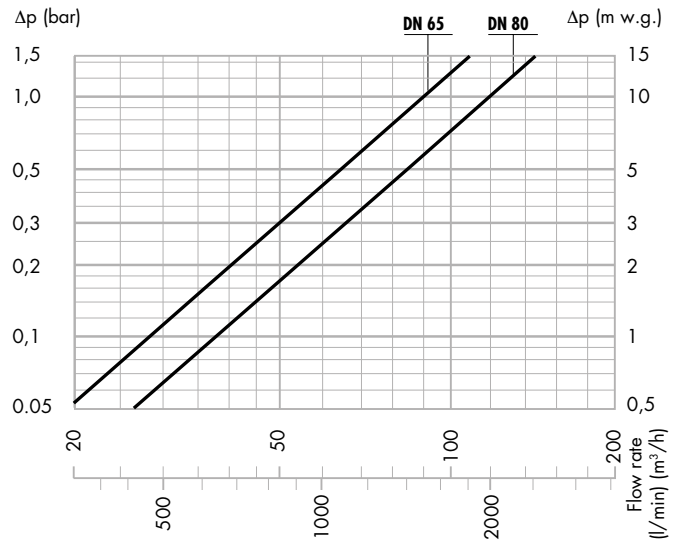
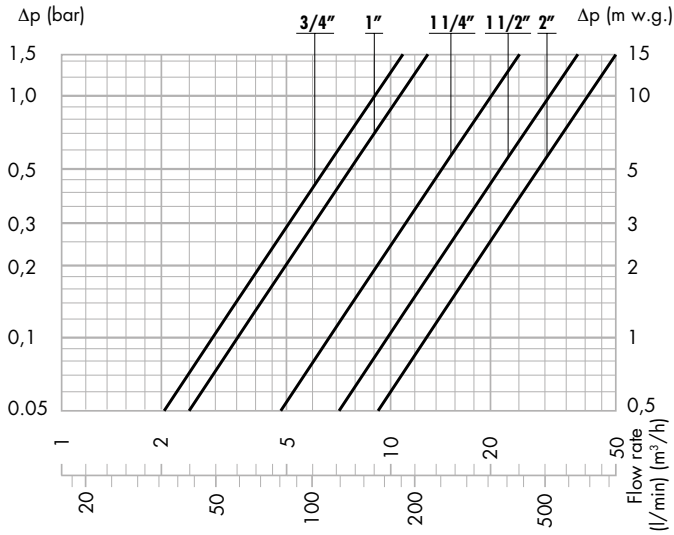

RECOMMENDED flow rates to ensure stable operation and an accuracy of $\pm 2\text{ }^\circ\text{C}$

	Kv (m ³ /h)
3/4"	8.4
1"	10.6
1 1/4"	21.2
1 1/2"	32.5
2"	41

	Minimum (m ³ /h)	Maximum* (m ³ /h)
3/4"	0.5	10.3
1"	0.7	13.2
1 1/4"	1.0	28.1
1 1/2"	1.5	39.0
2"	2.0	48.3

* $\Delta p = 1,5\text{ bar}$

RECOMMENDED flow rates to ensure stable operation and an accuracy of $\pm 2\text{ }^\circ\text{C}$

	Kv (m ³ /h)
DN 65	90.0
DN 80	120.0

	Minimum (m ³ /h)	Maximum* (m ³ /h)
DN 65	4.0	110.0
DN 80	5.0	146.0

* $\Delta p = 1,5\text{ bar}$

Back panel

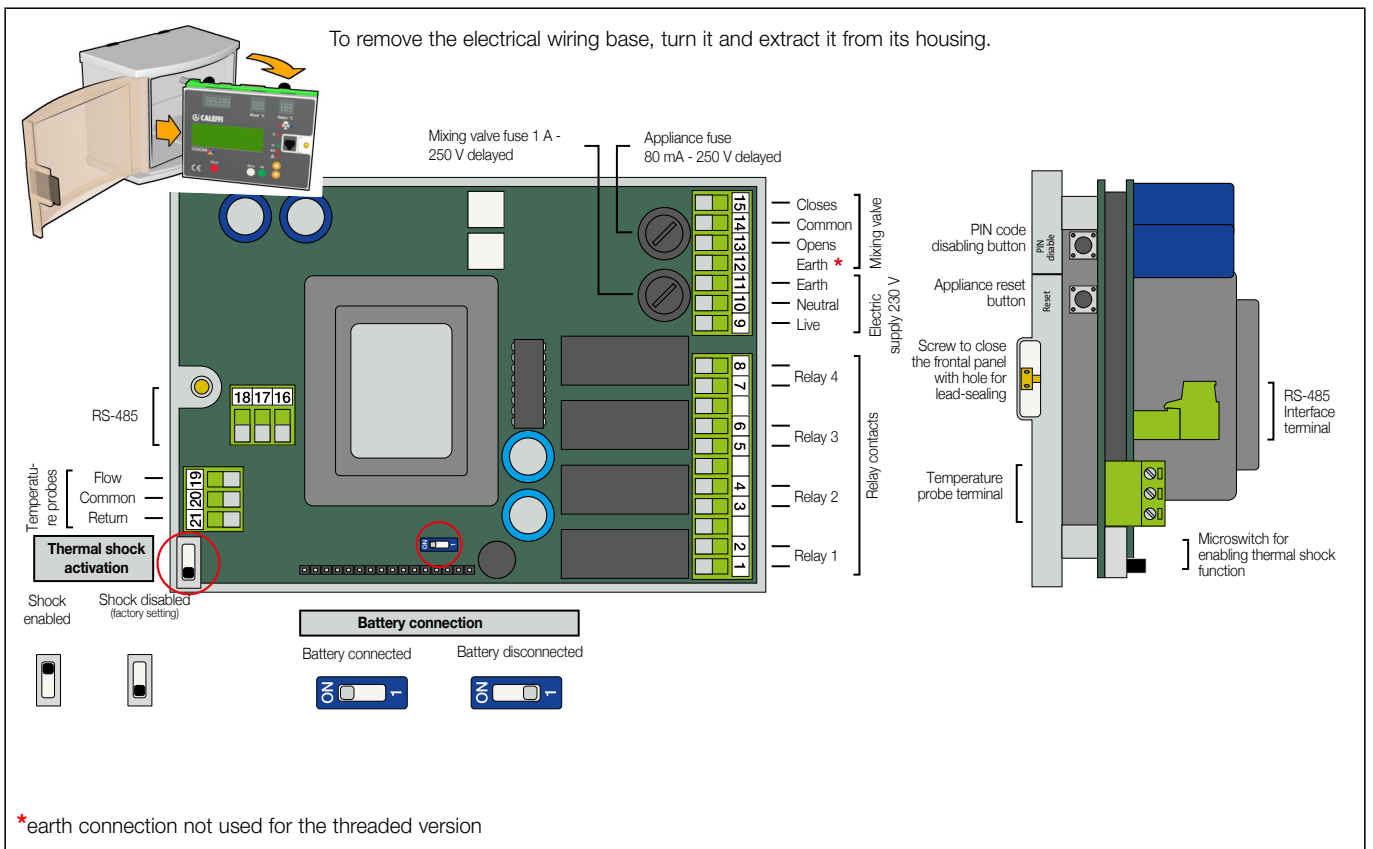

* earth connection not used for the threaded version

Front panel

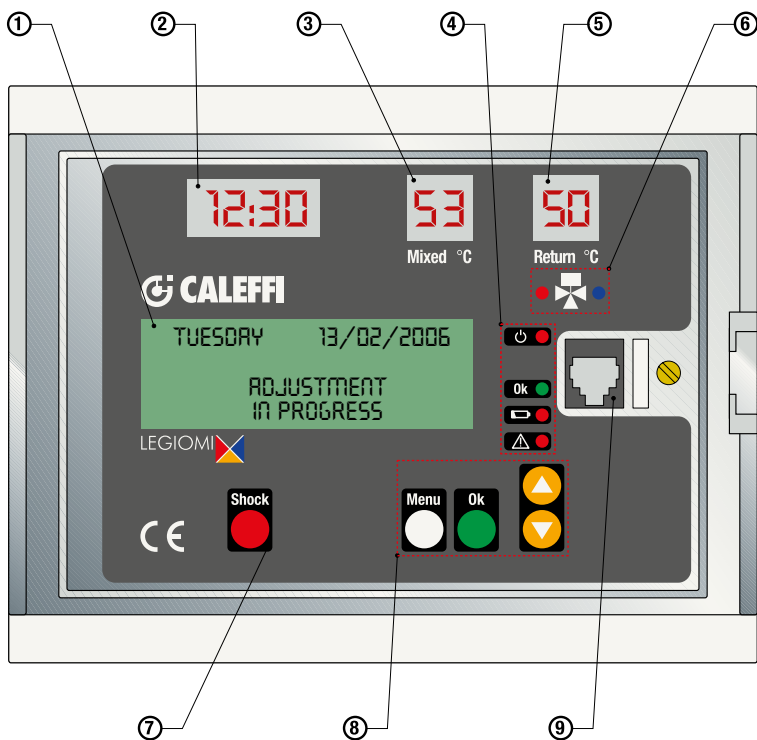

- 1 LCD display
- 2 LED display: HH:MM
- 3 LED display: TMixed-flow temperature
- 4 LED indicator
 - On
 - Status OK
 - Battery
 - Alarm
- 5 LED display: TReturn-return temperature
- 6 Mixing valve open/close LED
- 7 Thermal shock button
- 8 Navigation buttons
 - Menu
 - OK
 - ▲ UP
 - ▼ DOWN
- 9 RS 485 front connection

Indication description

Indications on LED display

On the front of the appliance there are 3 LED displays that constantly show the current time and the flow and return (system recirculation) probe temperatures.



Indications on LCD display

On the front of the appliance there is a green backlit alphanumeric display with four rows of 20 characters each, for setting parameters, programming work, displaying error messages and machine status. The buttons on the front panel ("MENU", "UP", "DOWN" and "OK") can be used to scroll through the menu items in order to configure the appliance, set the various parameters and view the temperature log.

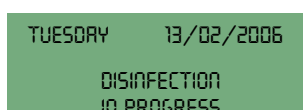
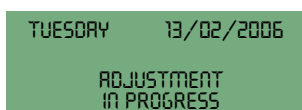

LED indicators

The following LED indicators are located on the front of the appliance:

Mains power LED:

 red led: steadily ON when mains voltage is present.

Mixing valve LED:

 Return °C

- open - red LED: lit when opening hot water
- close - blue LED: lit when opening cold water

Appliance OK status LED:

 green LED: steadily ON when there are no faults or active alarms.

Faulty battery LED:

 red LED: steadily on when there is a battery fault; otherwise off.

Generic Alarm LED:

 red LED: steadily ON when there is an alarm (probe fault, thermal shock in progress, reset)
Blinks when on low power.

Operating status

Depending on the times and the programs that have been set, the appliance may be in one of the following operating modes:

- **Adjustment;**
- **Disinfection;**
- **Flushing;**
- **Thermal shock** (this function has priority over the previous ones);

In the event of a trouble due to the appliance or the system, the device manages and reports the alarm and, depending on the situation, may maintain operation or not. In this context, a distinction is made between the following statuses:

- Active with alarm
- Inactive with alarm

The appliance is equipped with a rechargeable battery that keeps the clock working in the event of electric supply failure.

In the event of a blackout, in order to ensure the longest possible operating time for the battery, the appliance assumes the status:

- Inactive on Low Power.

Regulation

In this mode the appliance continually checks the temperature detected by the flow probe and adjusts the mixing valve accordingly so that the flow temperature is maintained at the programmed set point.

Disinfection

In this mode the appliance carries out a disinfection phase, which consists of raising the water temperature to a pre-set value for a specific time duration, by operating the mixing valve as required.

It is possible, using the menu, to set the days of the week on which disinfection must be carried out.

At the end of disinfection, the statistical data relating to the disinfection that has just been concluded are logged.

This mode begins and ends automatically at a start time (Time ON) and end time (Time OFF) that can be selected by the user.

CHECK ON DISINFECTION

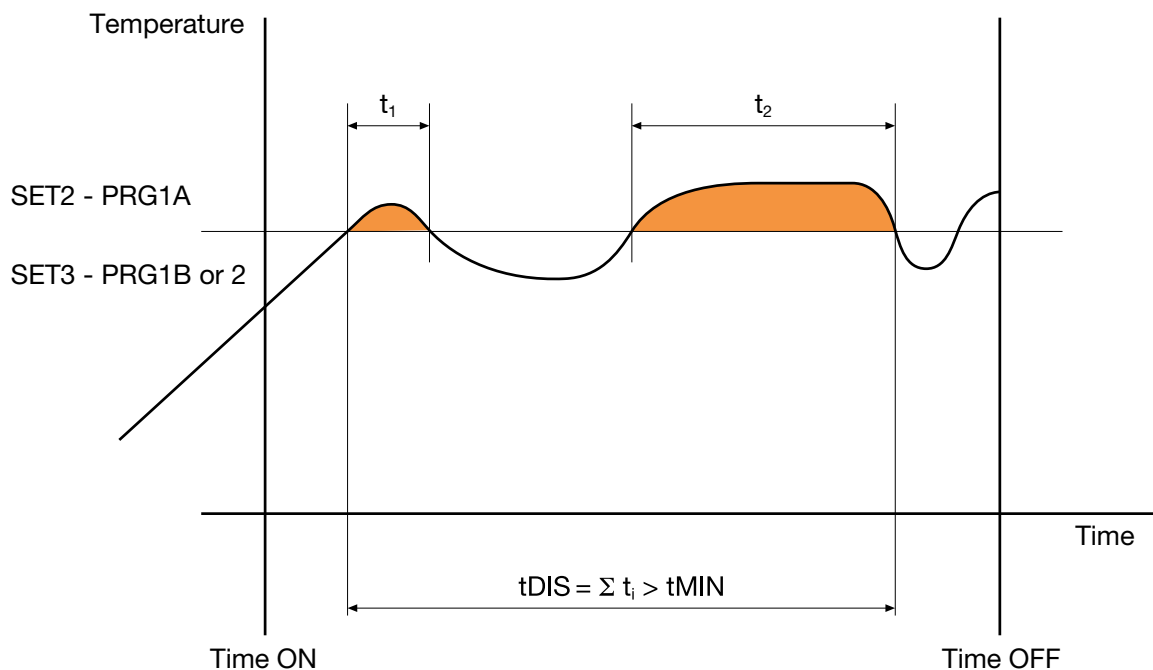

If, within the time span (Time OFF - Time ON), the actual disinfection time reached t_{DIS} is greater than the set t_{MIN} , the disinfection is concluded with a positive outcome. It automatically exits this status and returns to adjustment.

If it is not possible to reach a sufficient time t_{DIS} , the disinfection phase ends in any case at Time OFF.

Example:

Time ON: 2:00
 Time OFF: 3:00
 t_{MIN} : 30 min
 Program: 1A
 $T_{disinfection}$: 60 °C

If, in the time span of 1 hour, the temperature remains over 60 °C for at least 30 minutes, disinfection is successful and the regulator returns to adjustment mode. Otherwise, disinfection ends in any case at 3:00.

Programs

The operation of the regulator during disinfection can be set according to different programs, selected depending on the type of system and its management:

Program 0

This program features continual adjustment of the flow temperature with automatic disinfection in a time band that can be set. With this program the return probe is not used; if present, it is only used as a monitor.

During the disinfection phase, the flow probe temperature must remain above SET2 for a time tDIS at least equal to tMIN, if this occurs then disinfection has been successful.

As soon as there are the conditions to consider the disinfection successful, it is stopped. If the disinfection is not successful, there is no alarm signal.

Program 1A

This program features continual adjustment of the flow temperature with automatic disinfection in a time band that can be set. With this program the return probe is not used; if present, it is only used as a monitor.

During the disinfection phase, the flow probe temperature must remain above SET2 for a time tDIS at least equal to tMIN, if this occurs then disinfection has been successful.

As soon as there are the conditions to consider the disinfection successful, it is stopped.

If it is not possible to reach the disinfection temperature or it cannot be maintained for a sufficient period of time, the alarm for unsuccessful disinfection is generated. The alarm is recorded in the log.

The first time a button is pressed, the relay opens again.

The other alarm indications are cleared at the next successful disinfection.

Program 1B

This program can only be set if the return probe is set as present.

Identical to the previous program, the only difference being that the successful outcome of the disinfection phase is checked via the return probe in relation to SET3 instead of via the flow probe in relation to SET2.

As soon as there are the conditions to consider the disinfection successful, it is stopped.

If it is not possible to reach the disinfection temperature or it cannot be maintained for a sufficient period of time, the alarm for unsuccessful disinfection is generated.

The alarm is recorded in the log.

The first time a button is pressed, the relay opens again.

The other alarm indications are cleared at the next successful disinfection.

Program 2 (factory settings - default)

This program can only be set if the return probe is set as present.

Identical to the previous program, the only difference being that, if after a wait time tWAIT since the start of disinfection, the return temperature does not reach SET3, the flow temperature SET2 is increased by a value equal to (SET3 – TR reached), considering that SET2 cannot however exceed the limit SETMAX.

This correction procedure (increasing only) of the disinfection SET is iterative: if necessary, it is repeated in the time span defined by TimeON and TimeOFF at each time interval equal to tWAIT.

As soon as there are the conditions to consider the disinfection successful, it is stopped.

If it is not possible to reach the disinfection temperature or it cannot be maintained for a sufficient period of time, the alarm for unsuccessful disinfection is generated.

The alarm is recorded in the log.

The first time a button is pressed, the relay opens again.

The other alarm indications are cleared at the next successful disinfection.

Interrupting disinfection

Disinfection can be interrupted while it is still in progress. On the working screen (which shows the message “disinfection in progress”), press the OK button once. The display shows the message “Cancel disinfection?”; at this point, the OK button can be pressed to stop the disinfection and return to the adjustment function (without going through the flush phase).

If the OK button is not pressed, after a timeout of about 3 seconds, the display goes back to displaying the message “disinfection in progress”.

Table of thermal disinfection programs

Program	Use of return probe	Return probe shown on LED display	Adjustment temperature	Disinfection temperature	Alarm if disinfection unsuccessful	Recording in log if disinfection unsuccessful
0	NO	As monitor only	SET 1	SET 2	NO	NO
1A	NO	As monitor only	SET 1	SET 2	YES	YES
1B	YES	YES	SET 1	SET 3	YES	YES
2	YES	YES	SET 1	SET 3 +modify SET 2	YES	YES

Flushing

The appliance enters this mode automatically at the end of the disinfection phase and it can be used for example to make the water temperature return to the adjustment value more quickly or to clear periodically the storage of any impurities.

Thermal shock

In this mode, the appliance adjusts the flow temperature at the set shock value for a selectable time duration.

It is possible to start thermal shock by pressing the specific button on the appliance front panel (pressing and holding for at least 5") while the operating screen is displayed, or to program it with the menu item for a delayed execution (countdown in minutes), or by remote control.

After activating the procedure, it is anyhow possible to stop it by pressing the shock button and confirming with the "OK" button (guided procedure on the display), or by remote control.

At the end of the Thermal Shock phase, the appliance reverts to its "adjustment" function.

Low Power

This mode is entered in the event of a mains power failure.

The appliance continues to run the internal date clock; however, in this condition there is no power for switching the relays, so the regulator does not perform the adjustment or disinfection functions.

When the mains power comes back on, the blackout is recorded in the log and the regulator returns to operating mode as programmed, unless the mains failure lasted long enough to run down the battery completely. In this case the appliance will be reset when the mains power is restored. The factory settings are restored in the event of a reset or extended power failure.

ANTI-CLOG function

The regulator is configured so that it executes a daily ball movement cycle, to ensure efficient ball operation and cleaning. This procedure is carried out after the disinfection program, if active, or in any case after 24 hours have elapsed if the disinfection is not active. This function can be deactivated through the ANTI-CLOG item in the "SETTINGS" menu by entering the release code 5566 and confirming with ON-OFF.

Eliminating this function increases the risk of deposits forming on moving parts of the valve.

If it is necessary to eliminate the disinfection function as well, it is advisable to proceed in the following order: first eliminate the ANTI-CLOG function, then eliminate the disinfection function.

Reset



On the back panel there is a reset button, in case it is necessary to restore the initial settings.

If the date and time are not set after the reset, the regulator will only make the adjustment according to the default settings.

Actuation relays

The electric supply board and terminals show the relay contacts used to manage auxiliary equipment and to report alarms.

- Relay 1: circulation pump (**active during disinfection**).
- Relay 2: generic alarm (probe fault, battery fault, blackout or clock failure). This relay is connected through the NC contact.
- Relay 3: second thermostat.
- Relay 4: flushing valves.

Relay contact for recirculation pump and second storage thermostat

Below is the wiring diagram of relay 1 with a clock for managing the recirculation pump times.

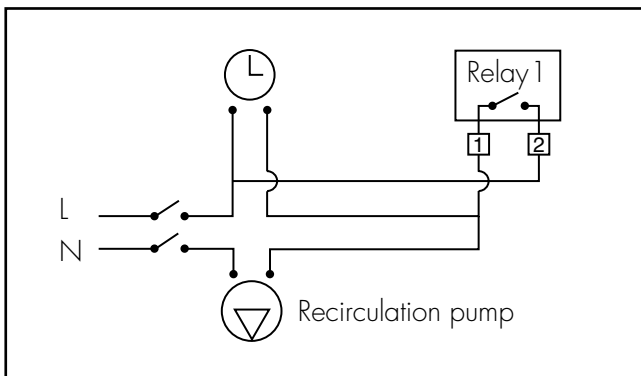

Below is the wiring diagram of relay 3 for connection to the second thermostat on the hot water storage.

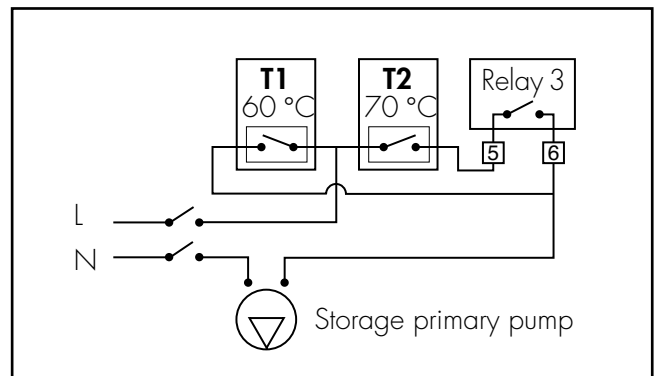

Alarm management

In order to simplify the solution of any functional problems after installation and commissioning, the regulator is configured so as to signal any operating trouble with alarms and to undertake the appropriate action.

In this case the cause of the alarm is shown on the LCD display.

If the alarm does not inhibit all the functions, the alarm screen will alternate with the appliance status screen.

Alarm description table

Alarm indicator	Description
AL1	Flow probe faulty
AL2	Return probe faulty
AL3	Disinfection failed
AL4	Thermal Shock in progress
AL5	Mains power failure
AL6	Appliance reset
AL7	Battery faulty

Depending on the type of alarm, certain actions are undertaken, relay statuses modified and information shown on the LED displays, LCD display and LEDs on the front panel.

For the operating details please refer to the installation and commissioning manual.

Log

The "log" is a FIFO list (loop buffer) that is continually updated and records parameters relating to the adjustment and disinfection phases that took place during the day.

The last 40 days are saved, after which the data relating to the less recent day are overwritten and so on.

Every hour, the hourly flow and return temperature averages are saved to Eeprom, while the alarms are saved at the time they occur.

At any time it is possible to view the average hourly values of the current day (obviously the ones already recorded).

Disinfection data are saved when disinfection ends.

It is possible to view the log on the display (via the specific menu item) or remotely via the RS485 serial interface.

The parameters saved in the log are:

- Date (day, month, year).
- Selected program. This is saved when disinfection starts.
- tDIS: actual disinfection time (in minute steps).
When the set program is 0 or 1A, this parameter is the time when the temperature of the flow probe was above SET2.
When the set program is 1B or 2, this parameter is the time when the return probe was above SET3.
This is helpful when it is less than tMIN, to understand how much greater the span of TIME ON: TIME OFF should be to complete the disinfection.
- TRMAX: maximum temperature of the return probe during disinfection (if a disinfection was completed on that day).
- TRMIN: minimum temperature of the return probe during disinfection (if a disinfection was completed on that day). It is calculated from the time when the return probe measured a value greater than SET3, i.e. from when the disinfection starts to be effective.
- Alarms AL1, AL2, AL3, AL4, AL5, AL6, AL7, if these had been activated during the day concerned.
- 24 hourly average flow temperature values.
- 24 hourly average return temperature values.
- Marker indicating whether the previous data are reliable. Used in the event of a reset, clock time adjustment, change of date and any other event that might have made the stored data unreliable.

If no disinfection was completed on that day, then the related fields will contain a default value.

If any faults have occurred in one or both probes, the hourly average data will be displayed by dashes.

If there are any "gaps" or unavailable data due to a change in date, time, etc., the cells will contain a default value and will be shown on the display by a few dashes.

```
LOG      06/04/2005
TDIS 060' PGRM 1A
TR MAX 58; TR MIN 48;
AL  ARM ---45-7-
```

```
LOG      06/04/2005
H 0 1 02 03 04 05 06
TR -----
TR -----
```

```
LOG      06/04/2005
H 0 7 08 09 10 11 1 2
TR 50 50 50 51 49 5 2
RT 474 7 474 7 46 48
```

Application diagrams

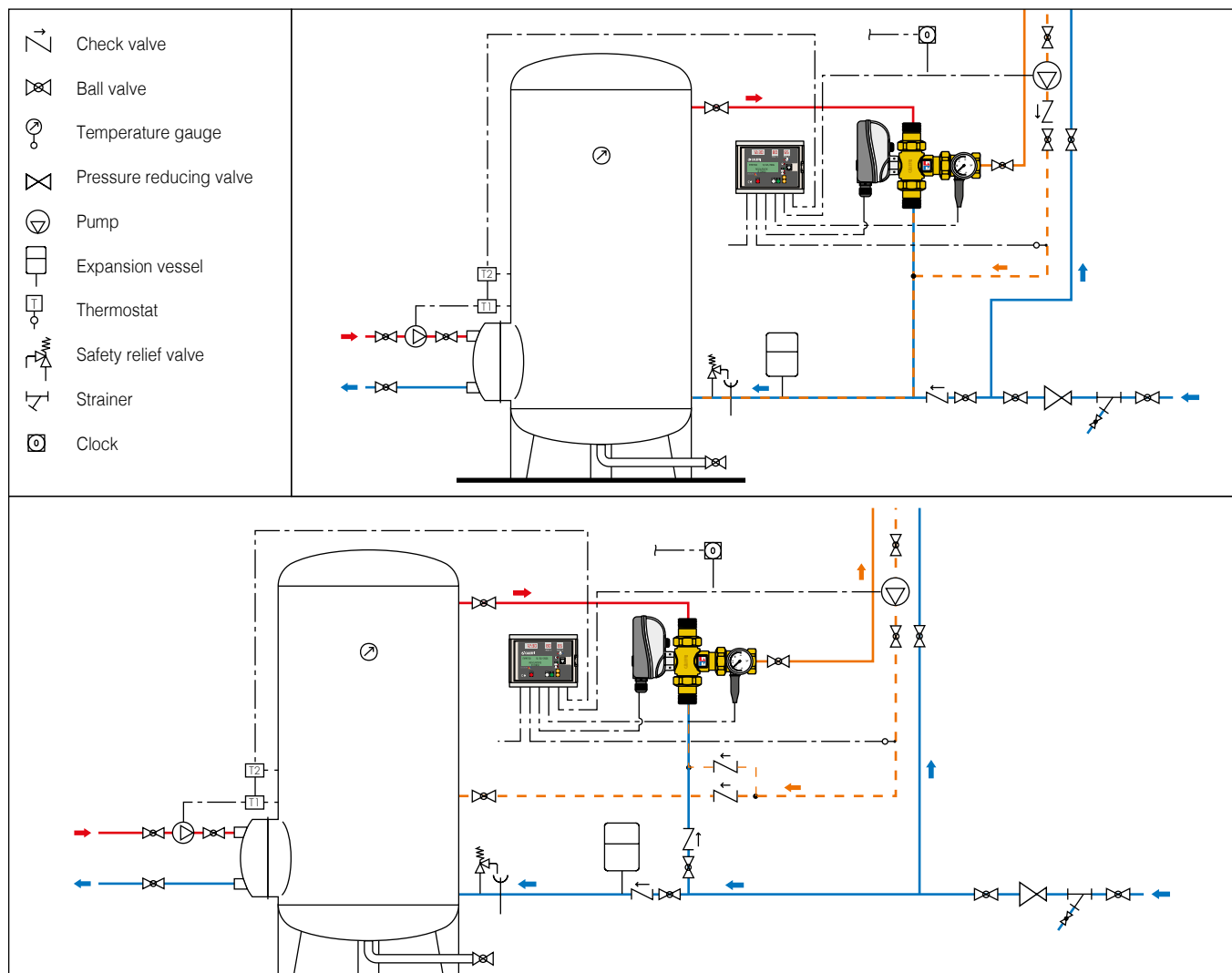

SPECIFICATION SUMMARY

6000 series threaded version

Electronic mixing valve with programmable thermal disinfection. Consisting of: **Valve body.** Hot and cold water connections threaded 3/4" (from 3/4" to 2"), with union, mixed water connection 3/4"F (from 3/4" to 2"). Brass body. Chrome plated brass ball (3/4"-1 1/4"), chrome plated brass with POM insert (1 1/2" and 2"). EPDM hydraulic seals. Maximum working pressure (static) 10 bar. Maximum inlet temperature 100 °C. Temperature gauge scale 0-80 °C. **Actuator.** Electric supply 230 V (ac) - 50/60 Hz directly from the regulator. Running power consumption 6 VA. Protection class IP 65. Ambient temperature range -10 – 55 °C. Self-extinguishing VO protection cover. Electric supply cable length 0,8 m. **Mixing valve.** Accuracy ± 2 °C. Maximum working pressure (dynamic) 5 bar. Max. inlet pressure ratio (H/C or C/H), with G = 0,5 Kv, 2:1. **Digital regulator.** Electric supply 230 V (ac) - 50/60 Hz. Power consumption 6,5 VA. Adjustment temperature range 20-85 °C. Disinfection temperature range 40-85 °C. Ambient temperature range 0-50 °C. With program for checking whether the thermal disinfection temperatures and times are actually achieved; equipped with a system for daily logging of the recorded parameters; fitted for connection to a monitoring or remote control device. Protection class IP 54 (wall mounting). Conforms to EC directives.

6000 series flanged versions

Electronic mixing valve with programmable thermal disinfection. Consisting of: **Valve body.** Flanged connections DN 65 (DN 65 and DN 80), PN 16 to be coupled with counterflanges EN 1092-1. Chrome plated brass body. Stainless steel ball. NBR hydraulic seals. Maximum working pressure (static) 10 bar. Maximum inlet temperature 100 °C. Temperature gauge scale 0-80 °C. **Actuator.** Electric supply 230 V (ac) - 50/60 Hz directly from the regulator. Running power consumption 10,5 VA. Protection class IP 65. Ambient temperature range -10 – 55 °C. Self-extinguishing VO protection cover. Electric supply cable length 2 m. **Mixing valve.** Accuracy ± 2 °C. Maximum working pressure (dynamic) 5 bar. Max. inlet pressure ratio (H/C or C/H), with G = 0,5 Kv, 2:1. **Digital regulator.** Electric supply 230 V (ac) - 50/60 Hz. Power consumption 6,5 VA. Adjustment temperature range 20-85 °C. Disinfection temperature range 40-85 °C. Ambient temperature range 0-50 °C. With program for checking whether the thermal disinfection temperatures and times are actually achieved; equipped with a system for daily logging of the recorded parameters; fitted for connection to a monitoring or remote control device. Protection class IP 54 (wall mounting). Conforms to EC directives.

LEGIOMIX® interface, code 600100



Function

The LEGIOMIX® interface (code 600100) allows the data transfer to a personal computer, both with local connection and with remote transmission via analogue modem or GSM. The supplied "telephone type" cable allows fast connection of the interface to the device by means of the connector on the front panel, which therefore means it is possible to use this software even in the absence of a centralised data transmission line.

- Complete with:
- RS232 interface-computer connection cable,
 - LEGIOMIX® -interface connection cable with telephone jack,
 - USB/serial port adapter,
 - transmission and management software.

Technical specifications

Electric supply: 230 V - 50 Hz - 5 VA.
 Dimensions: 165 x 120 x 40 mm.

Accessories

Code	
755845	analogue modem
755846	GSM digital modem
755855/N	bus cable (FROR 450/750 - 2x1 mm ²) - 100 m reel

Dimensions

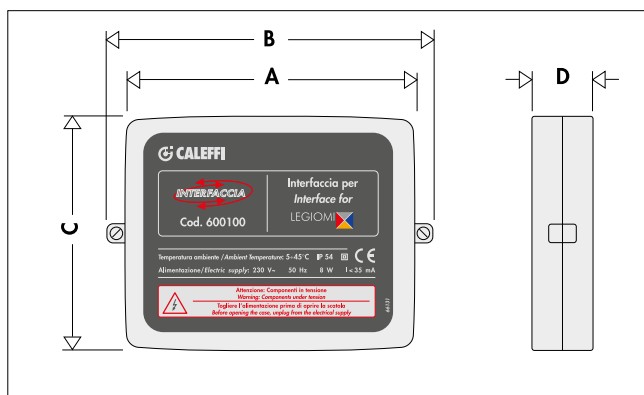

Code	A	B	C	D	Mass (kg)
600100	147	165	120	40	1.3

Application diagram

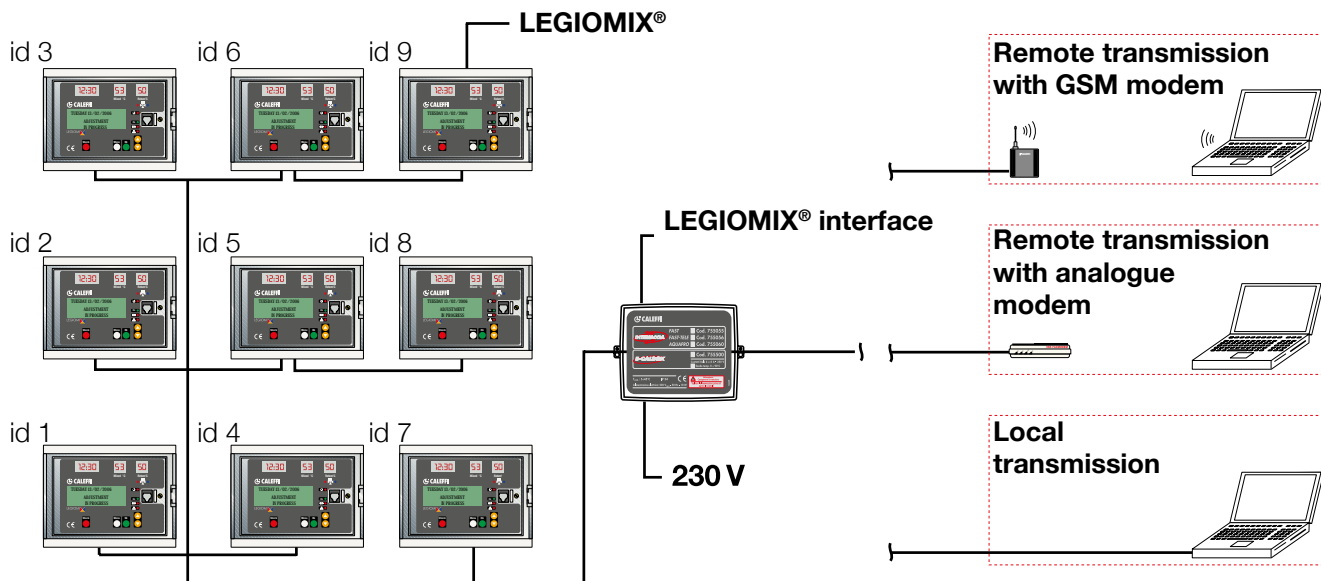

SPECIFICATION SUMMARY

Code 600100

LEGIOMIX® interface for data transmission and local or remote management of 6000 series electronic mixing valves. Complete with RS232 interface-computer connection cable, LEGIOMIX®-interface connection cable with telephone jack, USB/serial port adapter, transmission and management software. Electric supply 230 V - 50 Hz. Power consumption 5 VA.



Safety in use

As shown in the diagram opposite, temperatures over 50 °C can cause burns very quickly.

For example, at 55 °C, partial burn occurs in about 30 seconds, whereas at 60 °C partial burn occurs in about 5 seconds. On average, these times are halved for children and elderly people.

Depending on the type of system and its intended use, together with the relevant risk assessment, various devices can be installed to safeguard users from scalding caused by hot tap water.

Temperature - Exposure time

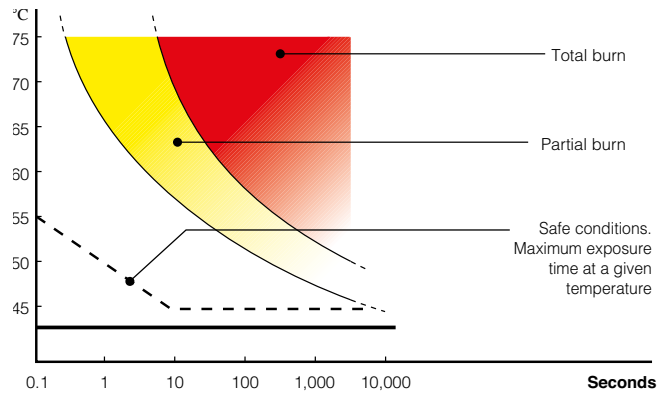

Anti-scald safety device for domestic hot water users, code 600140

Function



The function of the device is to cut off the flow of water if its temperature reaches the set value.

Suitable for application in hydraulic and domestic water systems fitted with electronic mixing valves with programmable thermal disinfection. Installed directly at the point of use outlet, it prevents the hot water from scalding the user during the thermal disinfection period ($T > 50$ °C).



Technical specifications

Materials

Body: brass EN 12164 CW614N, chrome plated
Springs: stainless steel

Maximum working pressure (static): 10 bar
Maximum working pressure (dynamic): 5 bar
Setting temperature: 48 °C (± 1 °C)

Connections: 1/2" F inlet
1/2" M outlet

Hydraulic characteristics

$K_v = 0,8$ (m³/h)

Dimensions

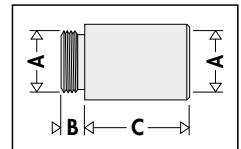

Code	A	B	C
600140	1/2"	8	38

Operating principle

Open

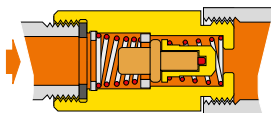

Closed

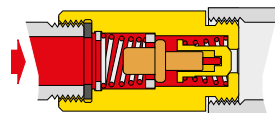

Application diagram

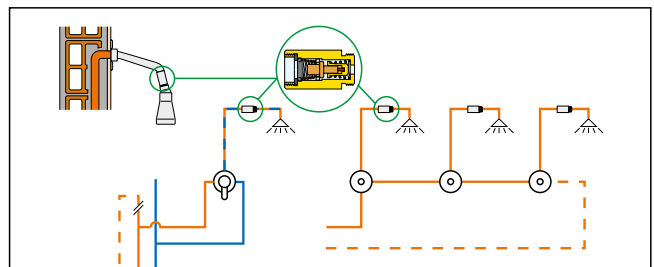

SPECIFICATION SUMMARY

Code 600140

Safety device for hydraulic and domestic hot water system user. Connections 1/2" F inlet x 1/2" M outlet Chrome plated brass body. Stainless steel springs. Maximum working pressure 10 bar. Setting temperature 48 °C (± 1 °C).

We reserve the right to make changes and improvements to our products and the related technical data in this publication, at any time and without prior notice.



Caleffi S.p.A.
S.R. 229 n. 25 · 28010 Fontaneto d'Agogna (NO) · Italy
Tel. +39 0322 8491 · Fax +39 0322 863305
info@caleffi.it · www.caleffi.it
© Copyright 2013 Caleffi