

DISCALDIRTMAG[®] magnetic air and dirt separator

5461-NA546_M series

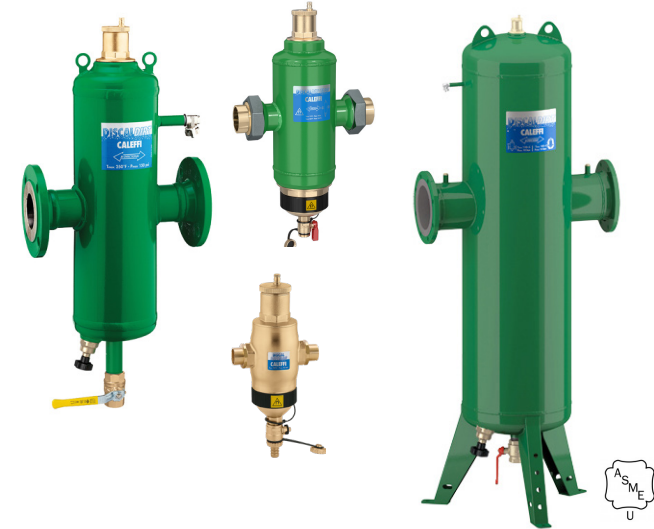

01287/21.1 NA
Replaces 01287/21 NA

Function

The Caleffi DISCALDIRTMAG[®] magnetic air and dirt separator incorporates three important functions for hydronic systems: air separation, dirt separation and ferrous impurity separation. An internal screen element facilitates the coalescing and capture of micro-bubbles to facilitate high performance automatic air removal, while concurrently causing the capture of non-ferrous debris particles down to 5 micron size. A powerful magnetic field induced by rare-earth neodymium magnets facilitates the capture of ferrous impurities such as iron oxide down to microscopic size thus delivering 2½ times the ferrous impurity removal performance of standard air and dirt separators.

The DISCALDIRTMAG saves on system installation and maintenance costs as three devices are combined into one. Additionally, all captured debris is blown down through the purge valve without taking the system offline. The circulation of fully de-aerated and cleaned water enables the equipment to operate under optimum conditions, free from noise, corrosion, or mechanical damage.

Insulation shells are available separately for field installation on the brass DISCALDIRTMAG.

Product range

5461 series	DISCALDIRTMAG air and dirt separator with magnet in brass.....	connections 1", 1¼" sweat & press, 1" NPT male
5461 series	DISCALDIRTMAG air and dirt separator with magnet in steel.....	connections 1½" and 2" sweat, NPT female and press union
NA546_M series	DISCALDIRTMAG air and dirt separator with magnet in steel, ASME.....	connections 2½" to 14" ANSI flanged, 2" NPT threaded -CRN approval for 2" – 12" sizes; consult factory for 14" sizes.

Technical specifications

Brass body magnetic air and dirt separators

Materials	- body:	brass
	- dirt separation chamber:	brass
	- air vent body:	brass
	- internal element:	glass reinforced nylon, PA66GF30
	- air vent float:	PP
	- air vent float guide pin:	stainless steel
	- air vent float linkages:	stainless steel
	- spring:	stainless steel
	- seals:	peroxide-cured EPDM
	- bottom drain shut-off valve:	brass
	- magnet:	neodymium rare-earth

Performance

Suitable fluids:	water, glycol solution
Max. percentage of glycol:	50%
Max. working pressure:	150 psi (10 bar)
Temperature range:	32–250°F (0–120°C)
Air separation efficiency:	100% removal to microbubble level
Particle separation capacity:	to 5 µm (0.2 mil)
Ferrous impurities separation efficiency:	up to 100% removal

Connections	- main:	1", 1¼" sweat & press; 1" NPT male
	- drain shut-off valve:	¾" garden hose (GHT)

Steel body magnetic air and dirt separators

Materials	- body:	epoxy resin coated steel
	- air vent body:	brass
	- mesh internal element:	(NA546_M) stainless steel (5461) stainless steel
	- air vent float:	PP
	- air vent float guide pin:	stainless steel
	- air vent float linkages:	stainless steel
	- spring:	stainless steel

- seals:	peroxide-cured EPDM
- bottom drain shut-off valve:	brass
- side drain shut-off valve:	brass
- magnet:	neodymium rare-earth
- magnet probe drywell (M series):	brass

Performance

Suitable fluids:	water, glycol solution
Max. percentage of glycol:	50%
Max. working pressure:	150 psi (10 bar)
Temperature range (vessel):	(M series): 32–270°F (0–132°C) (5461 series): 32–230°F (0–110°C)
Air separation efficiency:	100% removal to microbubble level
Particle separation capacity:	to 5 µm (0.2 mil)
Ferrous impurities separation efficiency:	up to 100% removal

Connections

- flanged:	2½"–14" ANSI B16.5 150 CLASS RF
- threaded:	(M series) 2" NPT male (5461) 1½" & 2" NPT female union
- sweat:	(5461) 1½" & 2" sweat union
- press:	(5461) 1½" & 2" press union
- bottom drain valve:	2"–6": 1" NPT female 8"–14": 2" NPT female
	5461 series: ¾" garden hose connection
- side drain shut-off valve (NA546_M only):	¾" GHT
- thermo well tap (8" only):	
- inlet/outlet flanges:	½" NPT female
- lay length (press connection):	size 1½ inch: 11 ¾" size 2 inch: 12 ⅞"

Agency approval

NA546_M series designed and built in accordance with Section VIII, Division 1 of the ASME Boiler and Pressure Vessel Code and tagged, registered with the National Board of Boiler and Pressure Vessel Inspector, and CRN registered, stamped for 150 psi (10 bar) working pressure, with ASME U stamp. 14" is CRN pending, consult Caleffi.

Dimensions

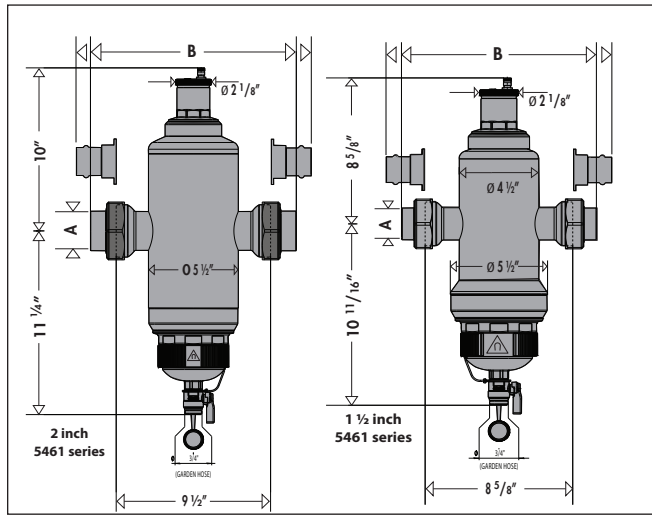

Code	A	B	Wt (lb)	Flow (gpm)	Cv
546198A	1 1/2" sweat	11 1/4"	22	22	50
546108A	1 1/2" NPT female	11 1/8"	22	22	50
546168A	1 1/2" press	14 5/8"	22	22	50
546199A	2" sweat	12 1/2"	23	39	79
546109A	2" NPT female	12"	23	39	79
546169A	2" press	15 3/4"	23	39	79

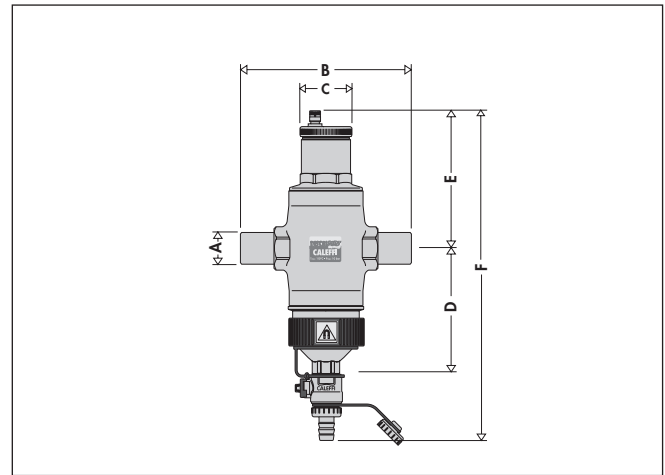

Code	Connections	A	B	C	D	E	F	Wt. (lb)	Wt. (kg)
546196A	Sweat	1"	7 3/8"	2 1/8"	5"	5 1/2"	12 3/4"	8.5	3.9
546197A	Sweat	1 1/4"	6 3/16"	2 1/8"	5"	5 1/2"	12 3/4"	8.5	3.9
546116A	NPT male	1"	7 3/8"	2 1/8"	5"	5 1/2"	12 3/4"	8.5	3.9
546166A	Press	1"	8 1/2"	2 1/8"	5"	5 1/2"	12 3/4"	8.5	3.9
546167A	Press	1 1/4"	8 7/16"	2 1/8"	5"	5 1/2"	12 3/4"	8.5	3.9

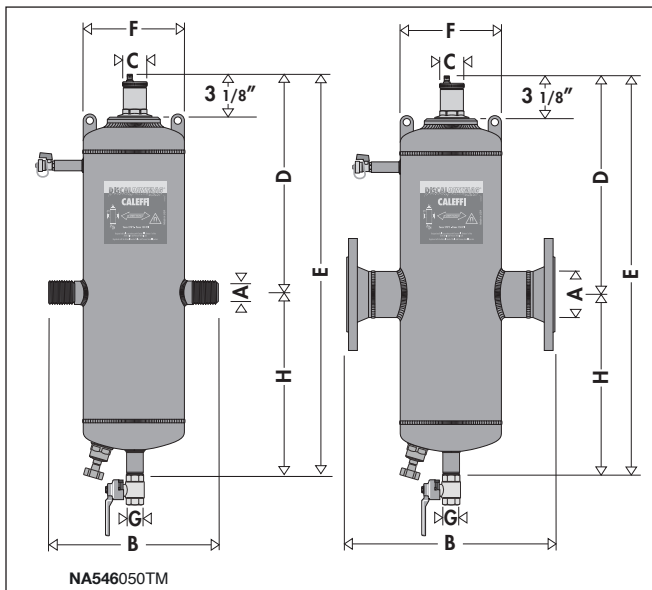

Code	A	B	C	D	E	F	G	H	Cap. (gal)	Wt. (lb)	Wt. (kg)
NA546050TM	2"	13"	2 3/16"	14 9/16"	28 3/4"	6 5/8"	1"	13 11/16"	3.6	31	14.0
NA546060AM	2 1/2"	13 3/4"	2 3/16"	14 9/16"	28 1/4"	6 5/8"	1"	13 11/16"	3.6	45	20.4
NA546080AM	3"	18 3/8"	2 3/16"	17"	34 1/2"	8 5/8"	1"	17 1/2"	7.6	76	34.5
NA546100AM	4"	18 1/2"	2 3/16"	17"	34 1/2"	8 5/8"	1"	17 1/2"	7.8	81	36.7
NA546120AM	5"	25"	2 3/16"	21 1/16"	46 11/16"	12 3/4"	1"	25 5/8"	22.4	184	83.5
NA546150AM	6"	25"	2 3/16"	21 1/16"	46 11/16"	12 3/4"	1"	25 5/8"	23.0	191	86.6

These models are ASME tagged and registered with the National Board of Boiler and Pressure Vessel Inspector and CRN registered. Consult Caleffi.

NOTE: Drawings may not reflect the actual size of the separators.

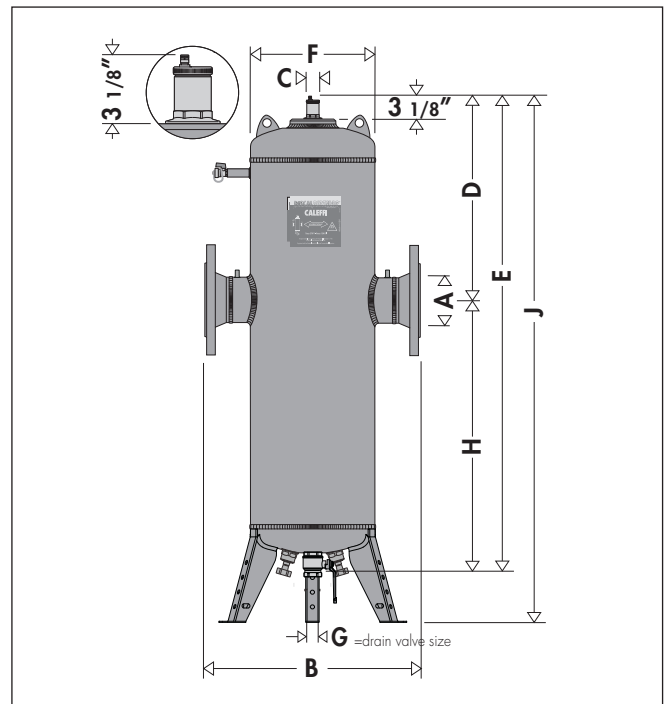

Code	A	B	C	D	E	F	G	H	J	Cap. (gal)	Wt. (lb)	Wt. (kg)
NA546200AM	8"	35 1/2"	2 3/16"	35 3/16"	82 7/8"	20"	2"	47 3/4"	94 3/4"	95	365	165
NA546250AM	10"	41 3/4"	2 3/16"	39 3/8"	91 11/16"	26"	2"	52 9/16"	103 5/8"	175	565	256
NA546300AM	12"	46 1/2"	2 3/16"	41 11/16"	98 9/16"	30"	2"	56 7/8"	110 1/2"	255	835	379
NA546350AM	14"	48"	2 3/16"	46 7/8"	112"	36"	2"	65 3/32"	123 7/8"	420	960	435

These models are ASME tagged and registered with the National Board of Boiler and Pressure Vessel Inspector and CRN registered. 14" is CRN pending, consult Caleffi.

The process of air formation

The amount of air which can remain dissolved in a water solution is a function of pressure and temperature. This relationship is governed by Henry's law and the graph demonstrates the physical phenomenon of the air release from water. As an example, at a constant absolute pressure of 30 psi (2 bar), if the water is heated from 65°F (18°C) to 170°F (75°C), the amount of air released by the solution is equal to 1.8 gallons of air per 100 gallons of water. According to this law it can be seen that the amount of air released increases with temperature rise and pressure reduction. The air comes in the form of micro-bubbles of diameters in the order of tenths of a millimeter.

In heating and cooling systems there are specific points where this process of formation of micro-bubbles takes place continuously in the boiler and in any device which operates under conditions of cavitation.

Solubility of air in water

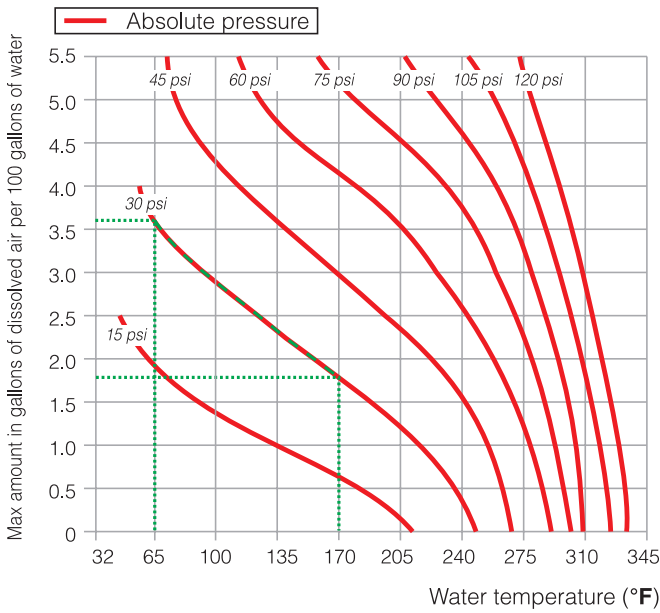

Cavitation and micro-bubbles

Micro-bubbles develop where the fluid velocity is very high with the corresponding reduction in pressure. These points are typically pump impellers and valve ports.

These air and vapor micro-bubbles, the formation of which is enhanced in the case of non-deaerated water, may subsequently implode due to the cavitation phenomenon.

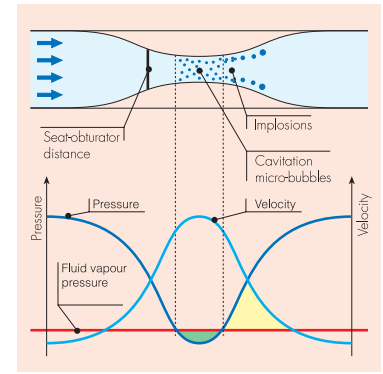

Boiler micro-bubbles

Micro-bubbles are formed continuously on the surface separating the water from the combustion chamber due to the fluid temperature. This air, carried by the water, collects in the critical points of the circuit from where it must be removed.

Some of this air is reabsorbed in the presence of colder surfaces.

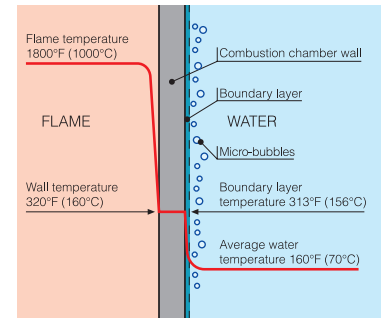

Operating principle

Microbubble air separation

The air and dirt separator uses the combined action of several physical principles. The active part is the internal element (1) and consists of a glass-reinforced nylon mesh for the brass DISCALDIRTMAG, or for the steel DISCALDIRTMAG an assembly of concentric metal mesh (stainless steel) surfaces. These elements create the whirling movement required to facilitate the release of micro-bubbles and their adhesion to these surfaces.

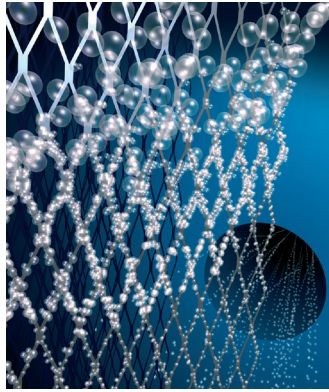

The bubbles, fusing with each other, increase in volume until the hydrostatic thrust is such as to overcome the adhesion force to the structure. They rise towards the top of the unit from which they are released through a float-operated automatic air vent valve.

Microparticle dirt separation

The dirt separating action performed by the same internal element (1) offers little resistance to the flowing medium while ensuring dirt separation. The particles collide with the concentric diamond pattern mesh surfaces and then settle to the bottom in the dirt collection chamber (2), and not by filtration unlike mesh strainers; which, over time, get progressively clogged. By contrast, the DISCALDIRT®'s low-velocity zone dirt separator function efficiently removes the particles to as small as 5µm (0.2 mil) with very low head loss. The dirt can then be removed through the bottom drain port (3).

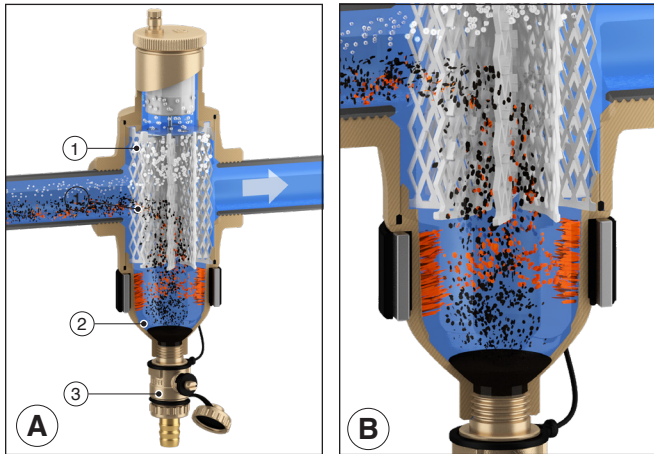

Ferrous impurities separation

Non-ferrous and ferrous impurities, including magnetite, in hydronic systems can deposit onto heat exchanger surfaces and accumulate in pump cavities causing reduced thermal efficiency and premature wear. The small and often microscopic magnetic particles, called magnetite, form when iron or steel corrodes. Highly abrasive, the extremely fine particles are difficult to remove by traditional means. DISCALDIRTMAG separators offer highly efficient separation of typical dirt as well as magnetite. The versatile DISCALDIRTMAG magnetic air and dirt separator removes both ferrous and non-ferrous impurities continuously. In addition to removing typical dirt particles with an internal element in a low-velocity-zone chamber, the DISCALDIRTMAG features a powerful removable magnet below the flow line for fast and effective capture of ferrous impurities. The magnet removes up to 100% of the ferrous impurities, including magnetite, that can form in a hydronic system.

For the 5461 brass and steel DISCALDIRTMAG (A,B,D), the ferrous impurities are captured by a strong neodymium rare-earth magnetic field created by a powerful removable magnet around the body below the flow line.

For the steel DISCALDIRTMAG NA546_M series (C), the ferrous impurities are captured by a concentrated magnetic field created by a stack of neodymium rare-earth magnets positioned inside a brass dry-well below the flow stream.

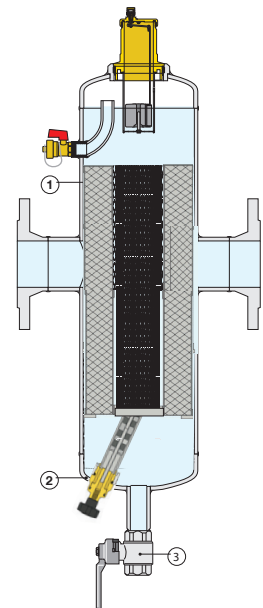
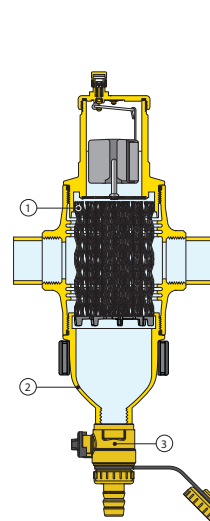
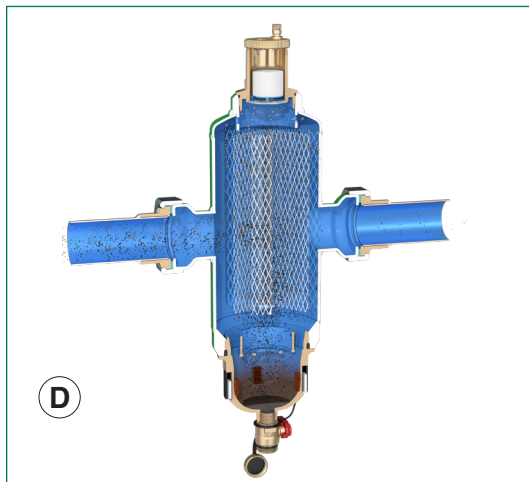
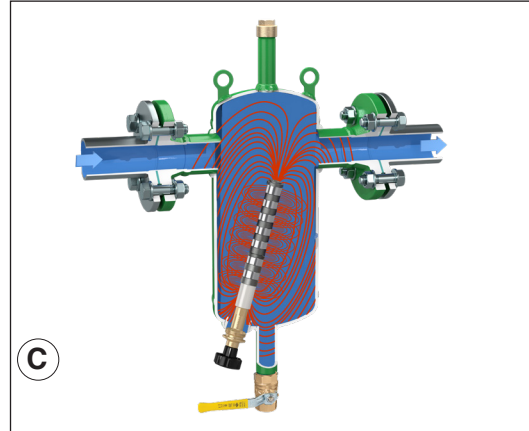

Brass DISCALDIRTMAG

Steel DISCALDIRTMAG
NA546_M series

Construction details

The DISCALDIRTMAG air and dirt separator is designed to be maintained and cleaned without removing it from system piping.

The automatic air vent, located at the top of the device, has a long chamber for float movement (2). This prevents any impurities in the water from reaching the seal seat. The corrosion resistant stainless steel pinned linkage and PP float can be accessed by removing the upper cover (1). The stainless steel float guide pin (4) prevents the float from jamming against the inside housing, sticking due to accumulating residue in the flowing fluids, in non-vertical installations or from boiler or chiller residue buildup.

Unscrew the top part of the casing (3) to clean the entire air venting system.

The air venting system in the brass DISCALDIRTMAG and steel DISCALDIRTMAG air and dirt separators features a pinned float.

Steel DISCALDIRTMAG air and dirt separators with flanged and threaded connections have an integral side drain port with shutoff valve, code 538402 FD (5), which has two functions:

1. Air removal while filling the system during system commissioning.
2. Debris removal that float within the air separator.

The drain valve (code NA39753 - 1 inch or code NA59600 - 2 inch) installed on the drain pipe at the base of the steel DISCALDIRTMAG air and dirt separator (8) can be used to remove any debris that has settled at the bottom of the separator, even while the system is in operation. To inspect the internal element of brass DISCALDIRTMAG air and dirt separators, unscrew the large dirt separation chamber (6) with a 26 mm hexagon wrench. The internal element can be removed for cleaning. Additionally, the brass air and dirt separators have a lever operated shut-off drain valve code 538402 FD, and 3/4" garden hose attachment with plug (7), to drain accumulated debris as needed.

Draining off dirt and ferrous impurities

The dirt separator collection chamber has a drain valve. Using the handle provided it is possible to drain off the accumulated dirt particles even with the system in operation.

For the brass DISCALDIRTMAG, captured ferrous impurities are easily flushed by unclamping the magnetic collar and purging.

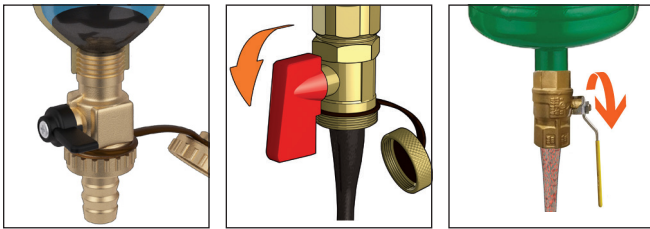

To purge the ferrous impurities in the steel DISCALDIRTMAG, the flexible magnetic stack is removed from the brass dry-well and, with the system still running, the drain valve is opened. Aided by the system pressure, the dirt and ferrous impurities, including magnetite, flushes out quickly and effectively.



Brass DISCALDIRTMAG

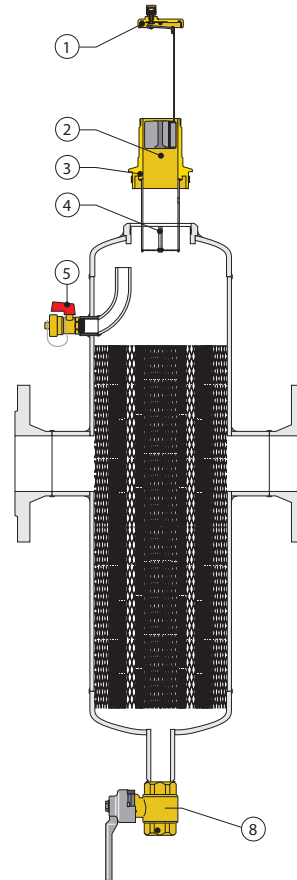
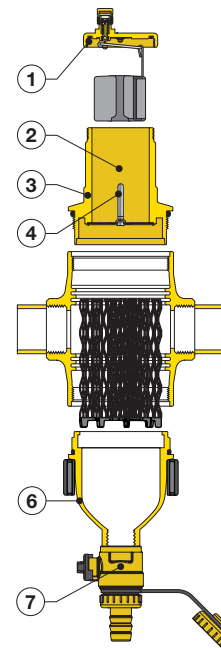

Steel DISCALDIRTMAG

Particle separation rating – dirt separator efficiency

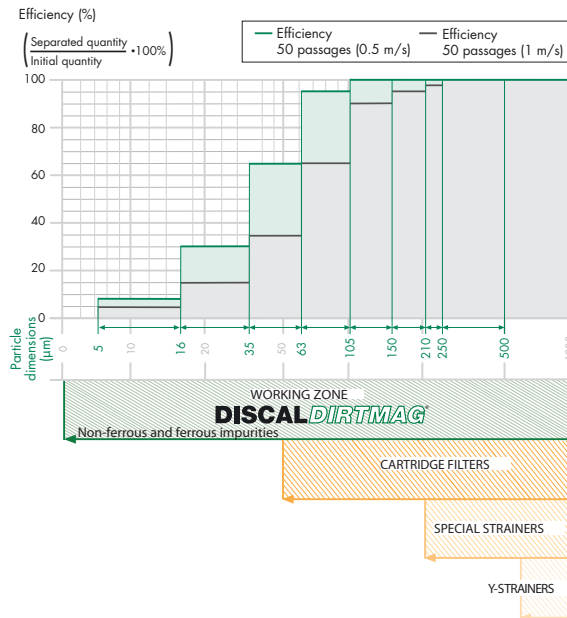

Separation efficiency

The capacity for separating the impurities in the medium circulating in the closed circuits of the systems basically depends on three parameters:

- 1) It increases as the size and mass of the particle increase. The larger and heavier particles drop before the lighter ones.
- 2) It increases as the speed decreases. If the speed decreases, there is a calm zone inside the dirt separator and the particles separate more easily.
- 3) It increases as the number of recirculations increases. The medium in the circuit, flowing through the dirt separator a number of times during operation, is subjected to a progressive action of separation, until the impurities are completely removed.

The special design of the internal element in the Caleffi DISCALDIRTMAG magnetic air and dirt separators, are able to completely separate the impurities in the circuit down to a minimum particle size of 5 µm (0.2 mil), including 100% ferrous impurities.

The particle separation — dirt separator efficiency graph (left) illustrates how DISCALDIRTMAG quickly separates nearly all the impurities. After only 50 circulations, approximately one day of operation, up to 100% is effectively removed from the circuit for particles of diameter greater than 100 µm (3.9 mil) and on average up to 80% taking account of the smallest particles. The continual passing of the medium during normal operation of the system gradually leads to complete dirt removal.

Hydraulic characteristics

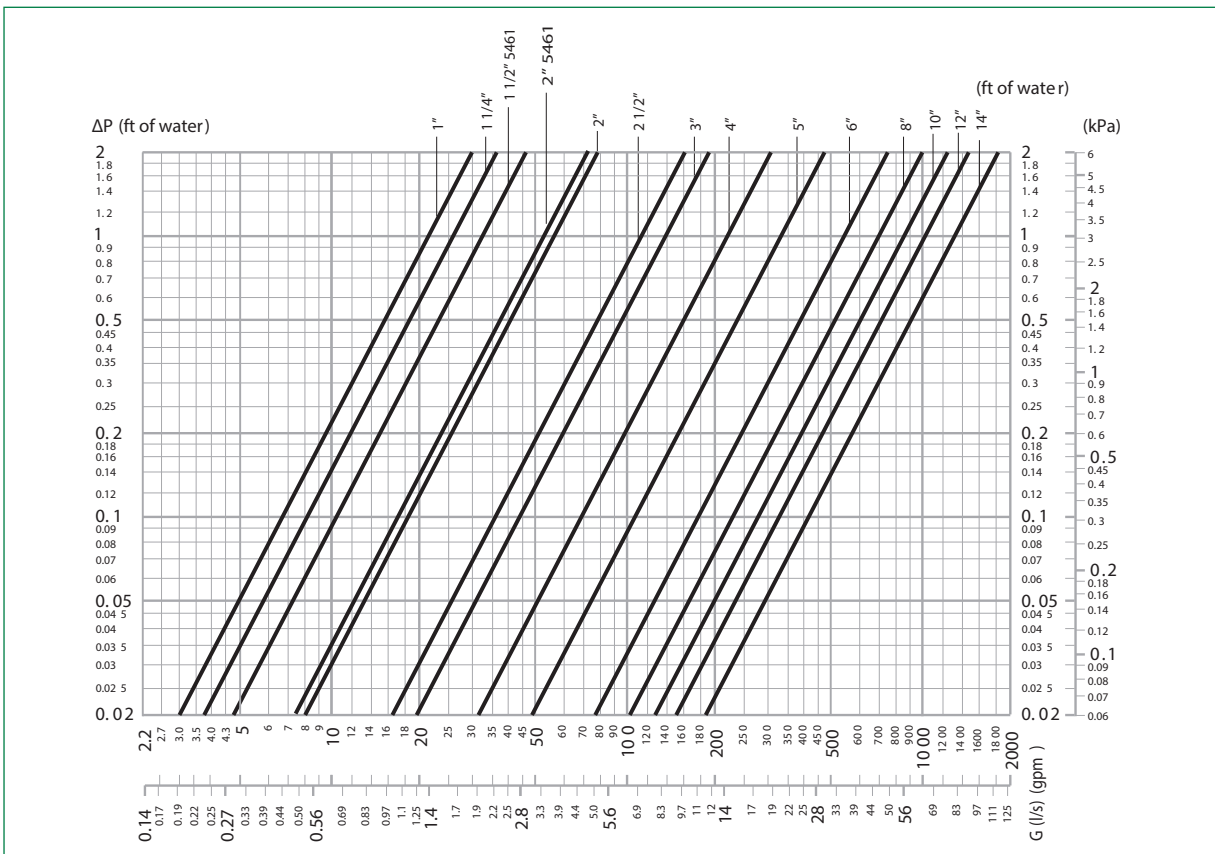

ft of water x .433 = psi

		Brass		Steel union		Steel flanged body									
		1"	1 1/4"	1 1/2"	2"	2"	2 1/2"	3"	4"	5"	6"	8"	10"	12"	14"
4.0 f/s	GPM	10	15	22	39	39	60	90	160	245	355	625	980	1,410	1,920
	l/s	0.63	0.95	1.04	2.5	2.5	4.0	6.0	10	15	22	40	62	89	121
10.0 f/s	GPM			55	98	100	155	220	400	615	880	1,570	2,450	3,525	4,800
	l/s			3.5	6.2	6.3	9.8	14	25	39	55	99	155	222	303
	Cv	32	40	50	79	87	174	208	324	520	832	1,109	1,387	1,664	1,967

Comparison of head losses: air and dirt separator to Y-strainers

Y-strainers entrap dirt within a basket made of stainless steel or brass mesh, selected for the size of the largest particle. Particles smaller than the mesh size may pass through. On most Y-strainers, the basket must be removed periodically to clear the trapped debris. As the debris collects in the basket, flow is impeded resulting in increasing pressure drop and therefore higher head loss. The dirt separation function in the DISCALDIRTMAG performs exactly as it does in the DIRTMAG®, utilizing the low-velocity-zone principle. The flow velocity of fluid flowing into the dirt separation chamber is greatly reduced causing the entrained dirt particles to drop due to their density.

The internal element provides surfaces that assist in separating dirt particles and guide them downward to ultimately settle to the bottom of the separator. The dirt separator only creates about 25% of the pressure drop of a comparable sized, clean basket strainer, depending on mesh size and amount of filtered debris. These head losses are not affected by the amount of dirt collected.

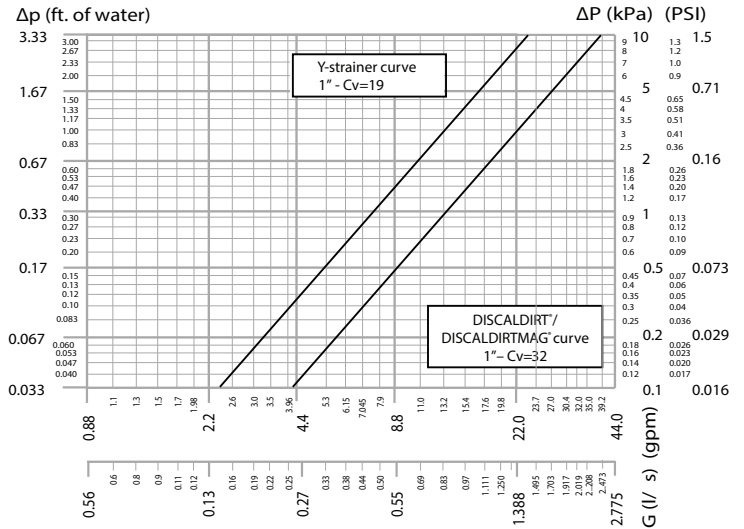

Insulation shells

The brass DISCALDIRTMAG 5461 series can be supplied with the optional insulated cover, code CBN546002 series (purchased separately), to minimize heat loss.

Technical specifications

Material: closed cell expanded PE-X
 Thickness: 25/64" (10 mm)
 Density: - inner part 1.9 lb/ft³ (30 kg/m³)
 - outer part: 5.0 lb/ft³ (80 kg/m³)
 Thermal conductivity (DIN 52612):
 - at 32°F (0°C): 0.263 BTU-in/hr-ft²·°F (0.038 W/(m·K))
 - at 104°F (40°C): 0.312 BTU-in/hr-ft²·°F (0.045 W/(m·K))
 Coefficient of resistance to water vapor (DIN 52615): >1,300
 Working temperature range: 32–230°F (0–110°C)
 Reaction to fire (DIN 4102): CLASS B2

Replacement parts

Drain valves (5) & (7), code 538402 FD. Drain valves (8), separator sizes 2" - 6", code NA39753; separator sizes 8" - 14", code NA59600.

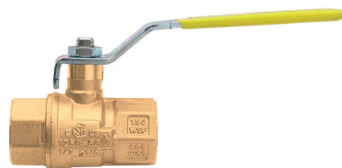

Removing insulation and draining impurities

1. Remove the insulation by taking off the bottom casing of the collection chamber first, and if necessary, the top insulation casing later.
2. Remove the magnetic ring containing the magnets, that during operation attracted the ferrous particles.
3. Flush out the ferrous and nonferrous debris by turning the handle to open the drain valve.
4. When finished, replace the insulation shells.

Code	Size
CBN546002	1", 1¼" Brass 546 only
CBN546118	1½" Steel 5461 only
CBN546119	2" Steel 5461 only

A replacement air vent assembly for the brass and steel DISCALDIRTMAG 5461 series is code 59829; for the steel DISCALDIRTMAG NA546_M series is code 59756.

The moving parts that control air venting are accessed simply by removing the upper cover. Replacement cap and float



assembly for all versions of the brass and steel DISCALDIRTMAG5461 series is code F39807.

When cleaning, simply unscrew the portion of the body containing the automatic air vent.

Installation

DISCALDIRTMAG units may be used in both heating and cooling systems, to ensure continuous air and dirt elimination. The units should be installed after the boiler and on the pump suction side, as these are the points where the formation of micro-bubbles is greatest.

DISCALDIRTMAG air and dirt separators must be installed vertically. In installation conditions where inspection is not possible, it is recommended that the venting valve cap is replaced by a Caleffi part number R59681 hygroscopic safety vent. The standard replacement cap code number is 59199.

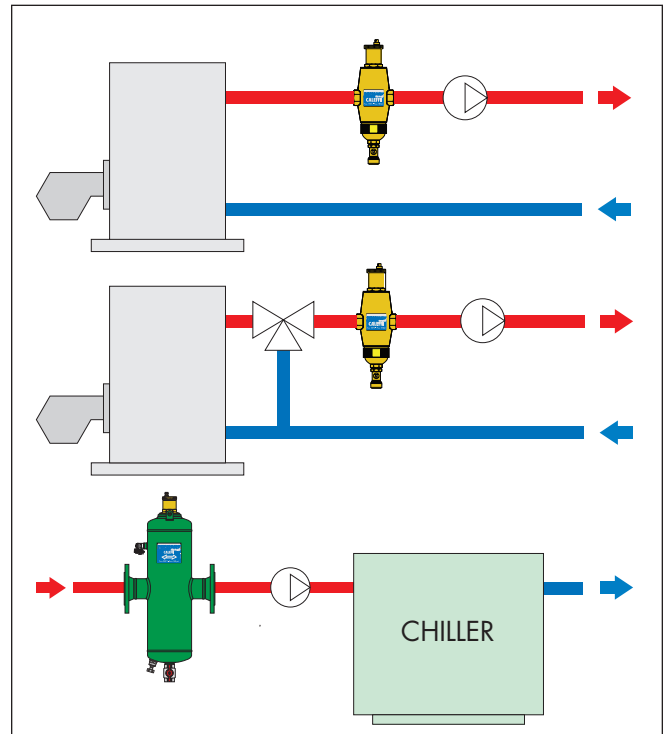
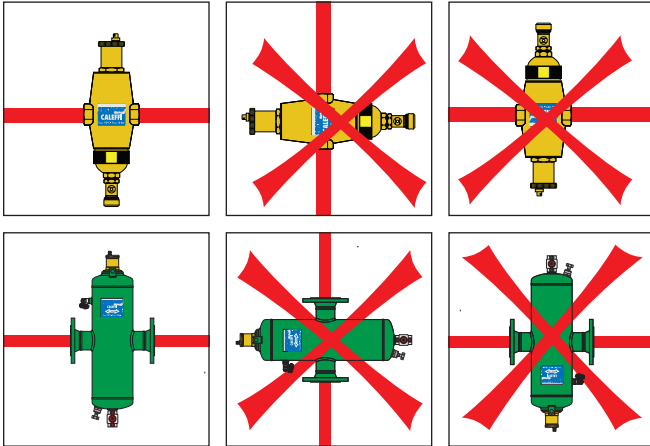

SPECIFICATION SUMMARIES

5461 series DISCALDIRTMAG – brass with sweat and NPT connections

Air and dirt separator with magnet complete with brass automatic air vent containing pinned float. Connections for horizontal pipes, sweat and press connections for 1" and 1¼" sizes, NPT male connection for 1". Brass body and dirt separation chamber with an external removable magnet belt, neodymium rare-earth. Peroxide-cured EPDM seals. Glass reinforced nylon PA66G30 internal mesh element, removable for cleaning. PP float. Stainless steel float linkages. Stainless steel float guide pin. Maximum working pressure, 150 psi (10 bar). Temperature range 32 to 250°F (0 to 120°C). Glycol maximum 50%. Air separation efficiency: 100% removal to micro-bubble level. Particle separation capacity: to 5 µm (0.2 mil). Ferrous impurities separation efficiency: up to 100% removal. Brass drain shut-off valve with ¾" garden hose connection. Pre-formed insulation shells available for field installation.

5461 series DISCALDIRTMAG – steel with union sweat, NPT and press connections

Air and dirt separator with magnet complete with automatic air vent containing pinned float. Connections for horizontal pipes, sweat union for 1½" and 2" sizes, NPT female union for 1½" and 2" sizes, and press union for 1½" and 2" sizes. Epoxy resin coated steel body with an external removable magnet belt, neodymium rare-earth. Peroxide-cured EPDM seal. Stainless steel internal mesh element. PP float. Stainless steel float linkages. Stainless steel float guide pin. Maximum working pressure, 150 psi (10 bar). Temperature range 32 to 230°F (0 to 110°C). Glycol maximum 50%. Air separation efficiency: 100% removal to micro-bubble level. Particle separation capacity: to 5 µm (0.2 mil). Ferrous impurities separation efficiency: up to 100% removal. Brass drain shut-off valve with ¾" garden hose connection.

NA546_M series DISCALDIRTMAG –flanged and NPT steel, ASME & CRN

Air and dirt separator with magnet, brass side drain valve and automatic air vent with pinned float. Flanged ANSI B16.5 CLASS 150 RF connections from 2½" to 14", and 2" NPT threaded connections, for horizontal pipes. Epoxy resin coated steel body with brass drywell for external removable neodymium rare-earth magnet, (quantity one for 2" - 2½" sizes-code 49684A, quantity one for 3" - 6" sizes-code 49685A, quantity three for 8" - 14" sizes-code F0000349) included. Peroxide-cured EPDM seal. Stainless steel internal mesh element. PP float. Stainless steel float linkages. Stainless steel float guide pin. Supplied with lever-operated drain ball valve brass body with 1" NPT female connection for separator sizes 2" - 6" - code NA39753; 2" NPT female connection for separator sizes 8" - 14", code NA59600. Side drain port supplied with integral brass shutoff valve, code 538402 FD, and ¾" garden hose connection. For separator size 8" - 14" only thermometer pocket well on inlet/outlet flanges ½" NPT female. Maximum working pressure, 150 psi (10 bar). Vessel working temperature range 32 to 270°F (0 to 132°C). Glycol maximum 50%. Air separation efficiency: 100% removal to microbubble level. Particle separation capacity: to 5 µm (0.2 mil). Ferrous impurities separation efficiency: up to 100% removal. The separator is designed and built in accordance Section VIII, Division 1 of the ASME Boiler and Pressure Vessel Code and tagged and registered with the National Board of Boiler and Pressure Vessel Inspector, and CRN registered (size 14" pending, contact Caleffi), and stamped for 150 psi (10 bar) working pressure, with ASME U stamp.

We reserve the right to change our products and their relevant technical data, contained in this publication, at any time and without prior notice.



Caleffi North America, Inc.
3883 W. Milwaukee Road
Milwaukee, WI 53208
Tel: 414-238-2360 · Fax: 414-238-2366
sales@caleffi.com · www.caleffi.com
© Copyright 2021 Caleffi North America, Inc.