

# Reduced pressure zone backflow preventer

## 574 series



1022/21.1 NA

Replaces 01022/21 NA



### Function

The backflow preventer can be used in all plumbing systems where there is danger of the potable water supply system being contaminated. It prevents an accidental reduction in the pressure in the distribution system from causing backflow from contaminated water in user installations.

The 574 series RPZ backflow preventer is ICC-ES certified to ASSE 1013, CSA B64.4 and NSF 372 low lead laws. It meets codes IPC, IRC, NPC and UPC for use in accordance with the US and Canadian plumbing codes. The 574 comes complete with PVC discharge air gap, all test ports are on top for easy access in spite of how the valve is mounted, union body connections make service and repair simple and fast, and a simple short list of parts is all that is required to do a rebuild.

Also available in combination with AutoFill™ pre-adjustable automatic filling valves, 1/2" and 3/4" sizes.

### Product Range

574 series Reduced pressure zone backflow preventer (ASSE 1013) with four pressure test ports and inlet/outlet isolation ball valves  
 .....sizes 1/2", 3/4", 1" and 1-1/4" NPT female, press

### Technical specification

- Materials**
- Body: DZR low-lead brass, EN 1982 CB752S
  - Access cover: DZR low-lead brass, EN 12165 CW724R
  - Access cover bolts: stainless steel
  - Check valves: PSU-POM-CW724R
  - Springs: stainless steel
  - Diaphragms and seals: peroxide-cured EPDM
  - Discharge air-gap: PVC
- Isolation ball valves, inlet and outlet
- Body: C898333 low-lead bronze
  - Ball: 304 stainless steel
  - Handle and nut: steel
  - Seat ring and packing gland: PTFE
  - Gland nut: brass
  - Stem: low-lead brass

### Performance

- Suitable fluids: Water
- Max working pressure: 150 psi (10 bar)
- Max working temperature: 150°F (65°C)

### Certifications

1. ASSE 1013/CSA B64.4, certified by ICC-ES, file PMG-1433.
2. Complies with NSF/ANSI 372, Drinking Water System Components-Lead Content Reduction of Lead in Drinking Water Act, California Health and Safety Code 116875 S.3874, as certified by ICC-ES, file PMG-1360.

### Connections

- NPT female: 1/2", 3/4", 1", 1-1/4"
- Press: 1/2", 3/4", 1", 1-1/4"
- Pressure test ports: 1/4" NPT upstream, intermediate, downstream

**Dimensions**

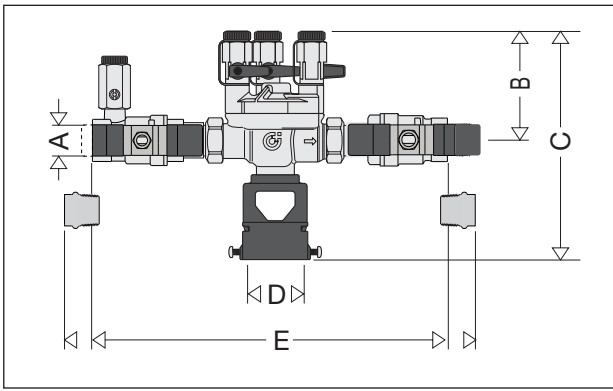

Code	A	B	C	D (mm)	E	Wt (lb)
574004A	1/2" FNPT	3 1/4"	6 1/4"	40 mm	9 3/4"	5.0
574064A	1/2" press*	3 1/4"	6 1/4"	40 mm	12 3/8"	5.1

\* Lay length: 10 7/8"

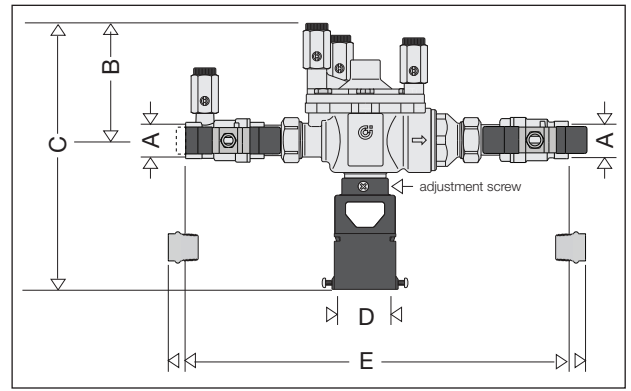

Code	A	B	C	D (mm)	E	Wt (lb)
574050A	3/4" FNPT	4"	10 1/2"	40-60 mm	13 1/4"	9.5
574056A	3/4" press*	4"	10 1/2"	40-60 mm	16 1/2"	9.6
574006A	1" FNPT	4"	10 1/2"	40-60 mm	14"	9.5
574066A	1" press*	4"	10 1/2"	40-60 mm	17 3/4"	9.6

\* Lay length: size 3/4 inch: 14 1/2"; size 1 inch: 15 7/8"

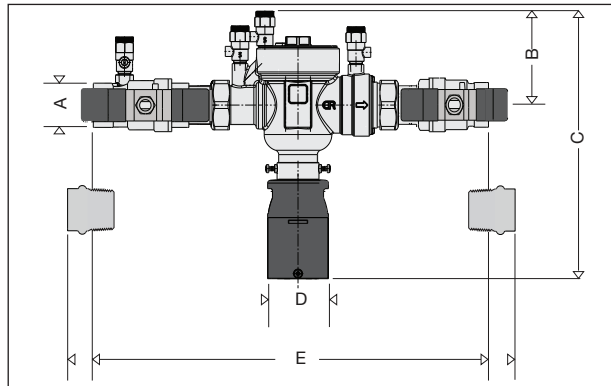

Code	A	B	C	D (mm)	E	Wt (lb)
574700A	1 1/4" FNPT	4"	11 1/2"	40-60	16 1/2"	13
574706A	1 1/4" press*	4"	11 1/2"	40-60	20 1/4"	13

\*Lay length: 18 1/4"

## Backflow:

Water flowing in the distribution piping of potable water mains systems can become polluted with undesirable and hazardous substances caused by contaminated fluid return coming back from systems directly connected to the mains supply. This condition termed "backflow" occurs when:

- a) the pressure in the mains supply is lower than the pressure in the downstream system (back syphon), such as residential domestic water, hydronic or irrigation systems. This occurs when pipes break or when demand is very heavy by other systems connected to the same supply network;
- b) the pressure in the downstream system rises (back pressure) due, for example, to water pumping from a well.

Protection can be provided by installing a backflow preventer at the inlet from the mains supply or in the internal distribution system. This will prevent contaminated water from flowing back into potable systems.

## Principle of Operation

The reduced pressure zone backflow preventer is composed of a body with an inspection cover, an upstream check valve (1), a downstream check valve (2), and a discharge valve (3). The two check valves divide three different zones, each with a different pressure: an upstream or inlet zone (A); an intermediate zone, also known as the reduced pressure zone (B); and a downstream or outlet zone (C). Each of these has a test port for pressure measurement. A discharge valve (3) is located in the lower part of the intermediate zone. The valve plug of the discharge valve is connected to the valve stem (4) and diaphragm (5). This moving unit is pushed upwards by the spring (6). The diaphragm (5) is the limit of the operation chamber (D), which is connected to the upstream zone by the channel (7).

### Normal flow conditions (1)

Under normal flow conditions, both check valves are open, while the pressure in the intermediate chamber (B) is always lower than the inlet pressure by at least 2 psi (14 kPa) due to the pressure loss caused by the check valve (1). In the operation chamber (D), however, the pressure is the same as in the inlet zone. In this situation, the moving unit consisting of the diaphragm (5), the valve stem (4) and the valve plug (3) is pushed down by the thrust created by the difference in pressure acting on the diaphragm which is greater than that of the spring (6) acting in the opposite direction. The discharge valve is therefore held in the closed position.

### No flow conditions (2)

The check valves (1) and (2) are now closed. Since the pressure in the upstream zone, and in the operation chamber (D), is still at least 2 psi (14 kPa) higher than the pressure in the intermediate chamber (B), the discharge valve remains closed.

### Upstream pressure loss (3)

Both check valves close as the pressure upstream drops. The discharge valve (3) opens when the difference in pressure  $\Delta p$ , between the upstream and the intermediate zones, falls reaching a value a little bit higher than 2 psi (14 kPa). Under these conditions the action exerted by the pressure difference  $\Delta p$  on the diaphragm (5) becomes weaker than that exerted by the spring (6) and the discharge valve (3) opens as a result. Discharge then occurs until the body of the backflow preventer is empty. When the situation returns to normal (pressure upstream greater than pressure downstream), the discharge valve closes and the backflow preventer is again ready to operate.

### Downstream back pressure

If the pressure in the downstream zone increases until it is greater than the upstream pressure, the check valve (2) closes and therefore prevents water already delivered from returning back into the mains system. If the seal of the check valve (2) is slightly defective or there is any other defect in the backflow preventer, the device always interrupts (disconnects) the connection between the mains system and the user system. The backflow preventer has been designed and certified to properly function, providing safe operation under all conditions.

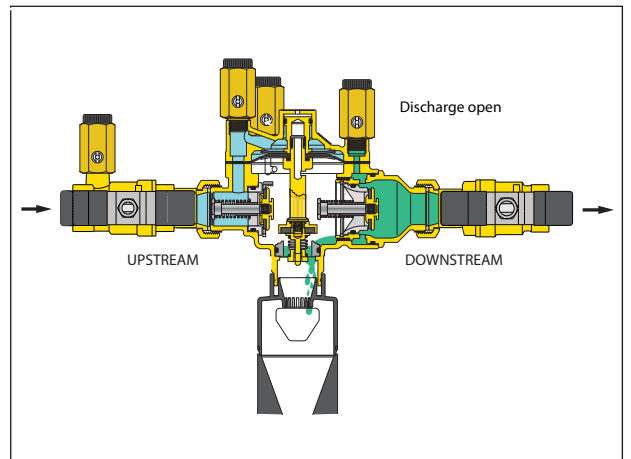
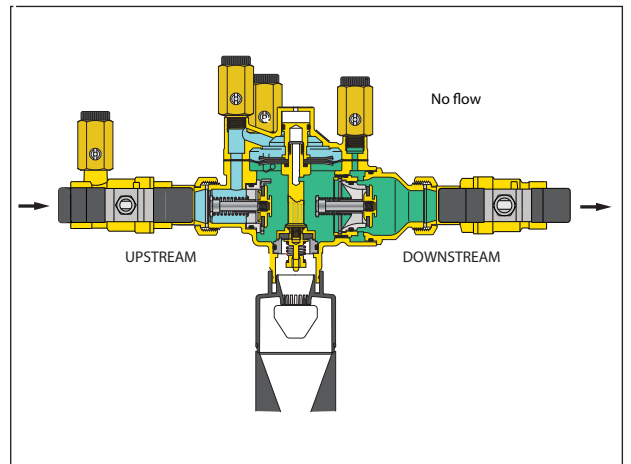
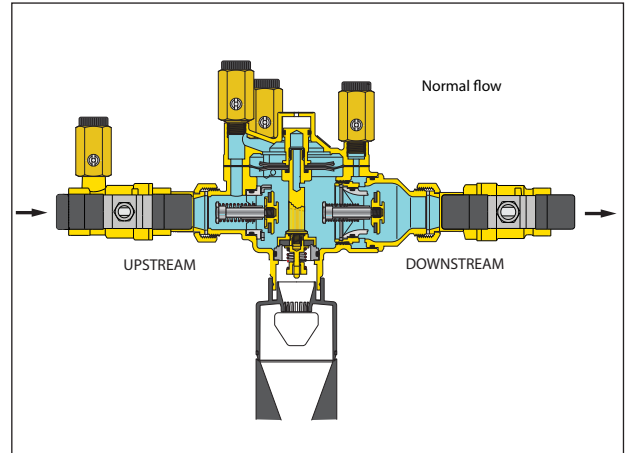

## Construction details

### Discharge air gap assembly

In compliance with ASSE 1013, proper location of the RPZ backflow preventer is to ensure that adequate drainage is provided to as not to cause damage to the surrounding area. The discharge is not to be piped directly to a drain without a proper air gap. The 574 series provides the PVC air gap discharge assembly for this purpose.

### Corrosion resistant materials of construction

All components are resistant to corrosion from potable water. DZR low-lead brass, stainless steel and bronze materials provide that protection to ensure long-time high performance.

### Easy maintenance

The backflow preventer must be periodically tested and inspected during normal operating life to ensure proper function. All internal components are accessible through a single access cover, secured with stainless steel bolts, for easy inspection, repair and replacement, including the seats (except 1/2" model size), without removing from the pipeline. Replacement check valves, discharge valve, inlet and outlet isolation ball valves and discharge air gaps are available separately.

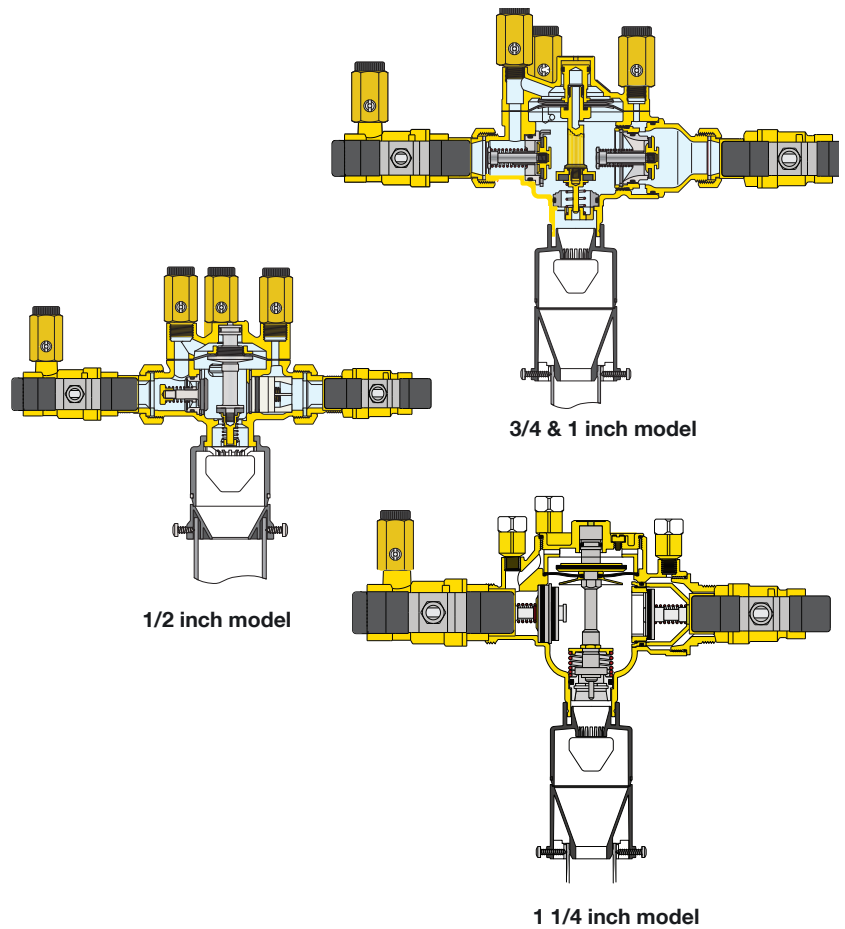

## Flow capacity

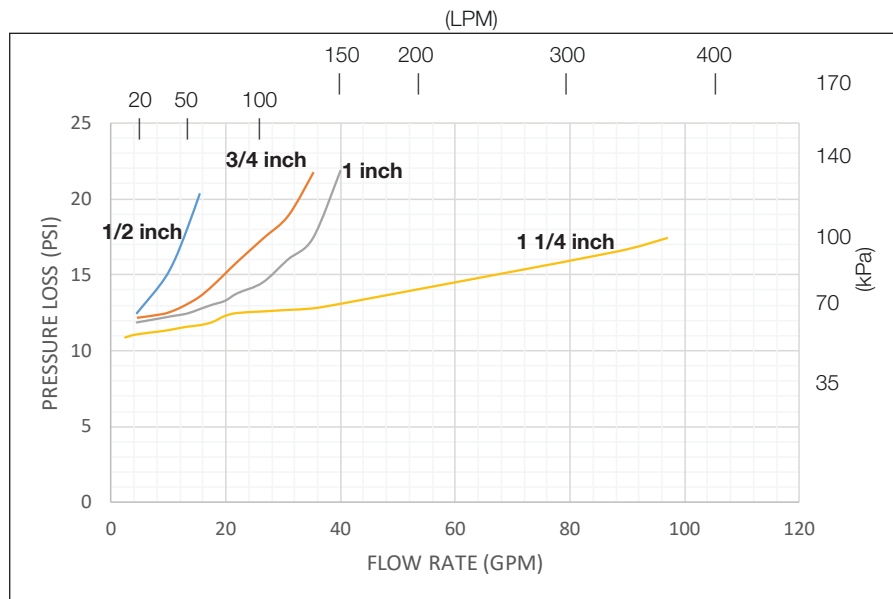

Size	Max. Cv
1/2 inch	3.5
3/4 inch	8.0
1 inch	12.0
1 1/4 inch	19.5

## Installation

The installation of backflow preventer should only be carried out by qualified personnel in accordance with applicable codes and regulations.

The backflow preventer includes an upstream and downstream shut-off valve.

Install the unit in an accessible area which is not susceptible to accidental flooding. The equipment is to be installed horizontally only. The air gap, complying with the ASSE 1013 standard, must be connected in accordance with local codes.

Before installing the backflow preventer the pipe should be cleaned.

To protect the main public supply system install the backflow preventer after the water meter. In an internal distribution system protect the supply side by installing the backflow preventer where contamination can occur, for example: centralized heating systems, garden water systems, etc.



## Installation diagram

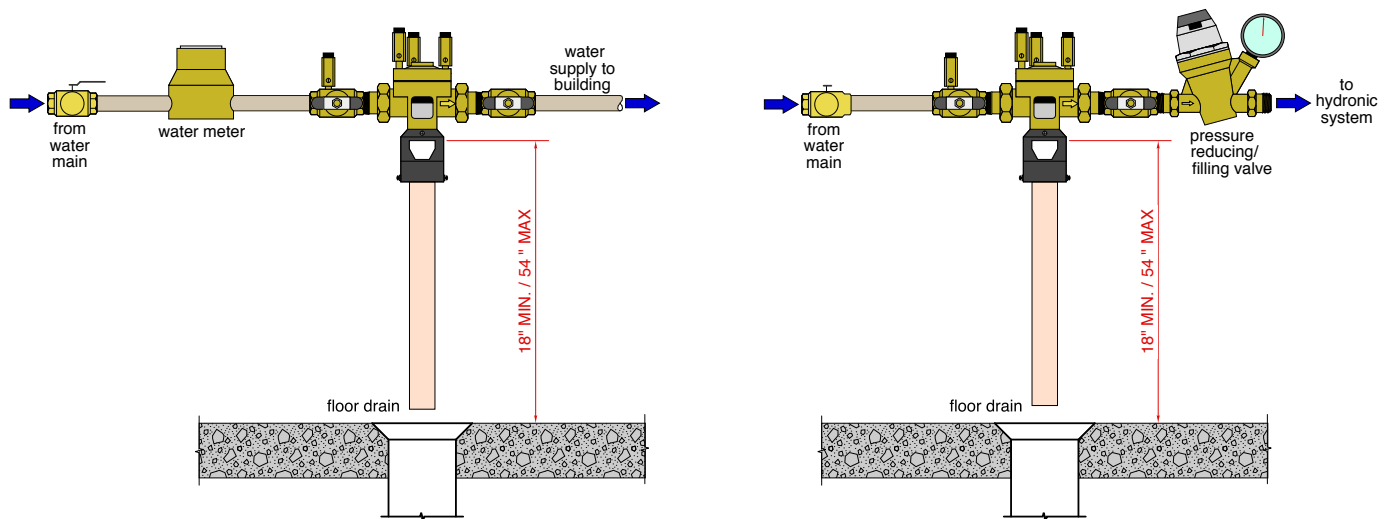

## Inspection and maintenance

The backflow preventer is a safety device and requires periodic inspection. The first sign of poor functioning, generally caused by the presence of foreign particles (sand or other impurities) keeping the upstream check valve in open position, is seen with a constant leakage from the discharge port. This discharge is only a first alarm and does not mean in any way that the check valve is not safe but the backflow preventer and the upstream strainer require dismantling and cleaning. A quick method of inspection (requires less than 15 minutes) is described in a table in the instruction sheet, shipped with the backflow preventer or available online at [www.caleffi.com](http://www.caleffi.com).

In case of leakage from the discharge port, a strong flow of water is recommended for some minutes by turning on one or more taps. This operation is often sufficient to flush out the foreign debris and return everything to normal conditions.

**574004A**  
**574064A**  
**(1/2")**

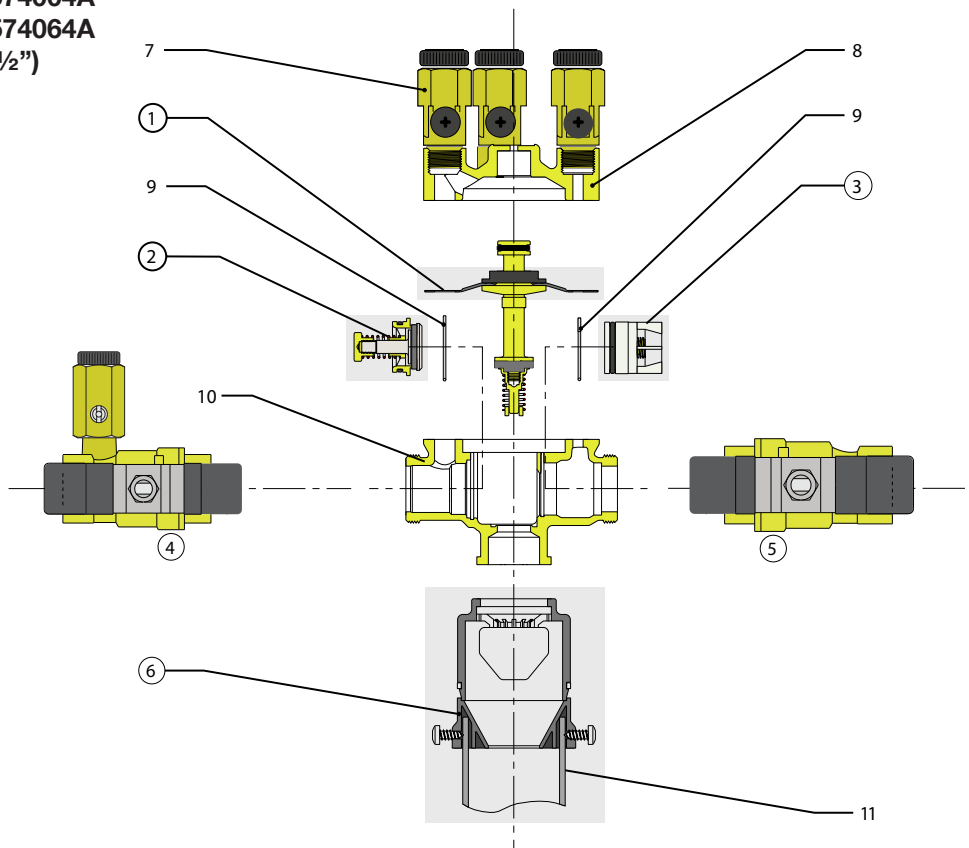

1	Discharge assembly
2	Upstream check valve
3	Downstream check valve
4	Upstream ball valve*
5	Downstream ball valve
6	Discharge air gap
7	Pressure test port
8	Inspection cover
9	Seal ring
10	Body
11	Discharge pipe**

\* Comes complete with PT port  
 \*\*1" PVC coupling plus 1" PVC pipe  
 or 1/4" PE4710 polyethylene  
 tubing (ASTM D-2239), separately  
 sourced.

Ref #	574004A 574064A	Backflow code #
1	59978	Spare part code #
2	59977	
3	59979	
4	F0001626	
5	F0001624	
6	59980	
7	F0001006	

For press models, press fittings are NPT male x Press, not shown above and not available from Caleffi. Source for modifying the NPT model, or to replace on press models, from any supply house. Be sure to use Loctite® to secure the threaded connection.

**Inspection equipment**

- Equipment for annual inspection includes:
- upstream pressure gauge
  - downstream pressure gauge
  - differential pressure gauge
  - flexible hoses and fittings

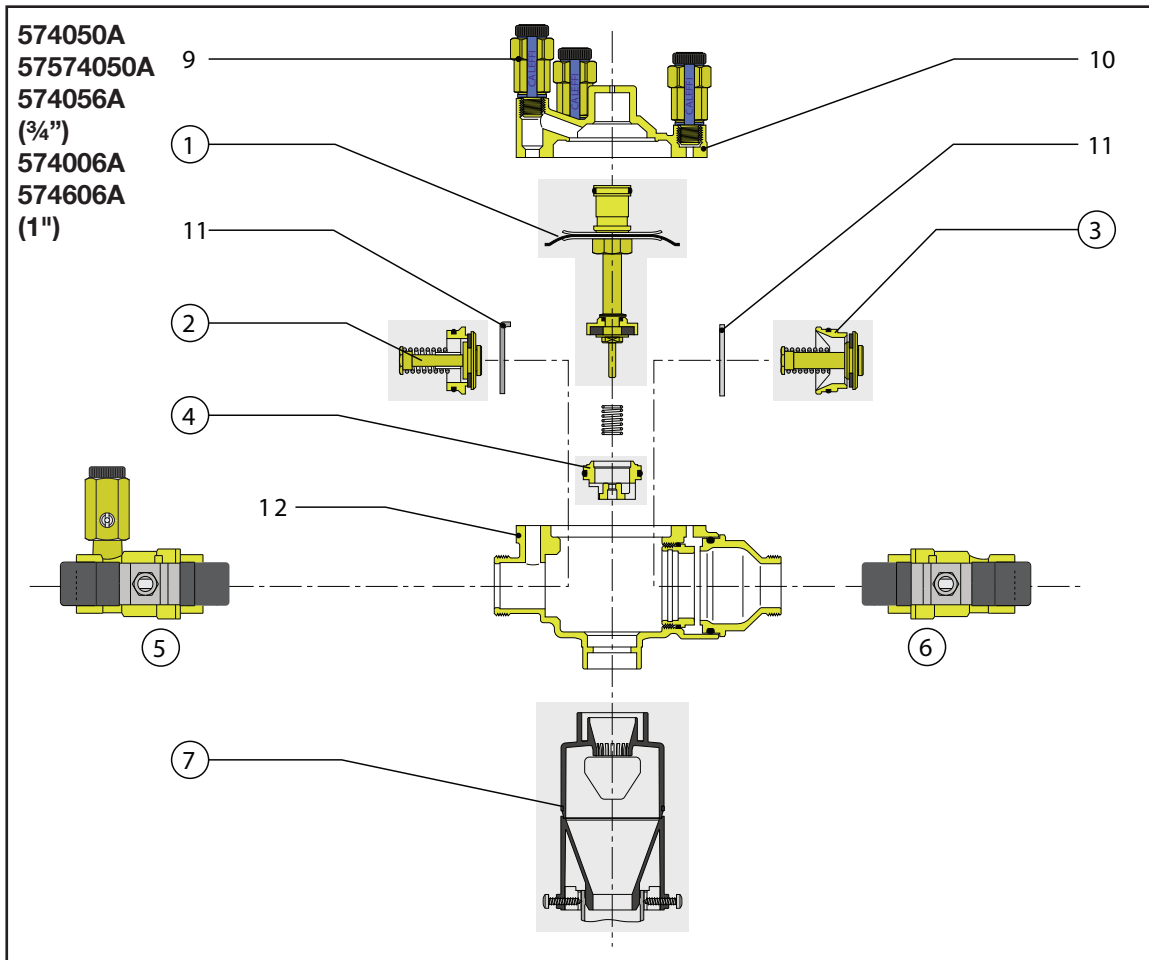

1	Discharge assembly
2	Upstream check valve
3	Downstream check valve
4	Discharge valve seat
5	Upstream ball valve*
6	Downstream ball valve
7	Discharge air gap
9	Pressure test port
10	Inspection Cover
11	Split ring
12	Body
13	Discharge pipe**

\* Comes complete with PT port  
 \*\*2" PVC or 1 1/4" PE4710 polyethylene tubing (ASTM D-2239), separately sourced.

NOTE: Call out for part 8 does not apply to this size.

Ref #	574050A 574056A (3/4")	574006A 574606A (1")	Backflowcode #
1	59471	59471	Spare part code #
2	59469	H0008485	
3	59470	H0008021	
4	59472	59472	
5	F0001627	F0001628	
6	F0001625	F0001629	
7	39623	39623	
9	F0001006	F0001006	

For press models, press fittings are NPT male x Press, not shown above and not available from Caleffi. Source for modifying the NPT model, or to replace on press models, from any supply house. Be sure to use Loctite® to secure the threaded connection.

#### Inspection equipment

- Equipment for annual inspection includes:
- upstream pressure gauge
  - downstream pressure gauge
  - differential pressure gauge
  - flexible hoses and fittings

**574700A**  
**574706A**  
**(1 1/4")**

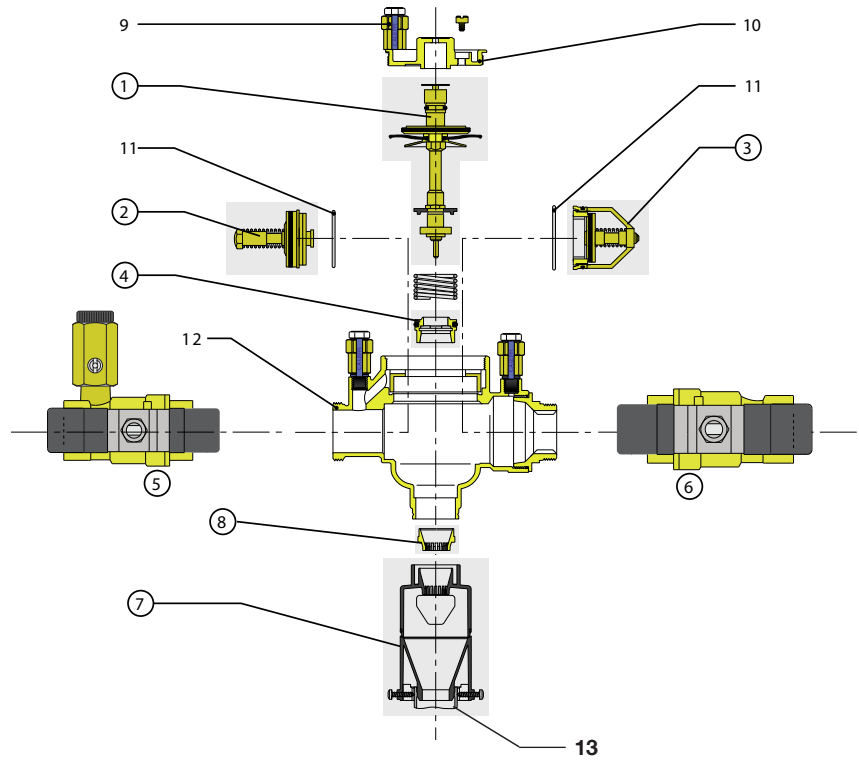

1	Discharge assembly
2	Upstream check valve
3	Downstream check valve
4	Discharge valve seat
5	Upstream ball valve*
6	Downstream ball valve
7	Discharge air gap
8	Deflector
9	Pressure test port
10	Inspection Cover
11	Split ring
12	Body
13	Discharge pipe**

\* Comes complete with PT port  
 \*\*2" PVC, separately sourced.

Ref #	574700A 574706A	Backflow code #
1	59457	Spare part code #
2	59455	
3	59456	
4	59458	
5	F0001631	
6	F0001630	
7	39623	

For press models, press fittings are NPT male x Press, not shown above and not available from Caleffi. Source for modifying the NPT model, or to replace on press models, from any supply house. Be sure to use Loctite® to secure the threaded connection.

Equipment for annual inspection includes:  
 -upstream pressure gauge  
 -downstream pressure gauge  
 -differential pressure gauge  
 -flexible hoses and fittings

---

## SPECIFICATION SUMMARIES

---

### 574 series

Testable reduced pressure zone backflow preventer. ASSE 1013/CSA B4.4 and NSF/ANSI 372 certified by ICC-ES. Threaded NPT female or press connections from 1/2" to 1 1/4". DZR low-lead brass body (EN 1982 CB752S) and access cover (EN 12165 CW724R) (<0.25% lead content), meets requirements of IPC, IRC, UPC, NPC and ANSI/NSF 372-2011 certified by ICC-ES. PSU-POM check valves, stainless steel springs, stainless steel access cover bolts and peroxide-cured EPDM diaphragm and seals. Maximum working pressure 150 psi (10 bar). Maximum working temperature 150°F (65°C). Provided with inlet and outlet isolation ball valves, bronze body, 304 stainless steel ball, steel handle and nut, PTFE seat ring and packing gland, brass gland nut and low-lead brass stem. Complete with upstream, intermediate and downstream pressure zone top-mounted test ports and PVC discharge air gap assembly with collar fitting to discharge pipe (separately sourced).

---

*We reserve the right to change our products and their relevant technical data, contained in this publication, at any time and without prior notice.*

---



Caleffi North America, Inc.  
3883 W. Milwaukee Road  
Milwaukee, WI 53208  
Tel: 414-238-2360 · Fax: 414-238-2366  
sales@caleffi.com · www.caleffi.com  
© Copyright 2021 Caleffi North America, Inc.