



Product Features

- wetted metal parts made from dezincification-free and corrosion-resistant gunmetal, resistant against aggressive water
- maintenance-free spindle gasket with self-lubricating EPDM lip gasket
- EPDM-seat gasket
- flange connection
- with sidewise drain valve, rotatable hose connection element G 3/4
- with test port
- check valve with SST spring
- with a black handwheel
- free from dead spots
- for any installation position
- with shut-off function

Standards and Approvals

- according to DVGW regulations
- plastic parts with KTW and W 270 approval
- according to accepted materials list from German environmental agency
- acc. to DIN EN 13959 provisions / DIN EN 558-1
- ÜA-Reg.-Nr. R-15.2.3-21-17048, WIEN-ZERT

Technical Data

- pressure rating PN 16
- max. operating temperature 100 °C

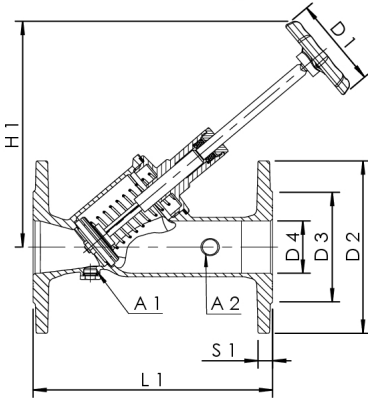

part no.	DN	bolt holes	A1	A2	D1 (mm)	D2 (mm)	D3 (mm)	D4 (mm)	H1 (mm)	L1 (mm)	S1 (mm)	Zeta	$\Delta p_{opening}$ (hpa)	cv (m ³ /h)	kg
1370205000	50	4	G 1/4	G 3/8	90	165	102	50	220	230	14	2,3	70	64,7	6,533
1370206500	65	4	G 1/4	G 3/8	120	185	122	65	293	290	15	2,1	120	116	10,377
1370208000	80	8	G 1/4	G 3/8	120	200	138	80	326	310	16	3,8	140	130	12,863
1370210000	100	8	G 1/4	G 3/8	120	220	158	100	302	350	18	3,8	140	186	19,099

accessory

- gunmetal sampling valve, figure 187 00
- backing ring for stub flange, figure 410 00
- stub flange, figure 425 00
- threaded flange, figure 426 00
- gasket, figure 428 00